

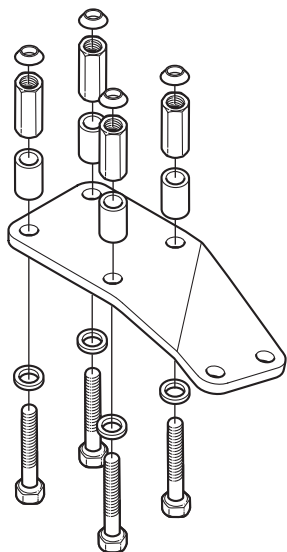

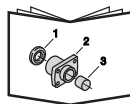

**VW Crafter  
MB Sprinter**

**56-243000  
56-322001**



- DE** **Blattfederung**  
Einzelbereift
- DK** **Bladfjedre**  
Singelmonterede hjul
- FI** **Lehtijousitus**  
Yksittäispyörä
- FR** **Suspension à lames**  
Roue simple
- GB** **Plate suspension**  
Single wheel
- IT** **Sospensioni a balestra**  
Ruota singola
- LV** **Pļāksnes pakarināšana**  
Vienkāršais ritenis
- NO** **Bladfjæring**  
Enkelthjul
- PL** **Zawieszenie plytki**  
Pojedyncze koło
- SE** **Bladfjädring**  
Singelhjul

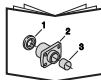

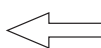
	Montageanleitung Monteringvejledning Asennusohje	Instructions de montage Mounting instruction Istruzioni di montaggio	Montāžas instrukcija Monteringsanvisning Instrukcja montażowa Monteringsanvisning
	Ersatzteilliste Reservedeliste Varaosaluettelo	Liste des pièces détachées Spare Parts List Parti di ricambio	Rezerves daļu saraksts Reservedeliste Lista czæúci zamiennych Reservdelista
	Anleitungen des Herstellers Producentens anvisning Valmistajan ohjeet	Instructions du fabricant Manufacturer's instruction Istruzioni del produttore	Ražotāja norādījumi Produsentens anvisning Wskazówki producenta Tillverkarens anvisning
	Anweisungen des LKW-Herstellers Lastbilfabrikantens anvisning Ajoneuvon valmistajan ohjeet Instruction du constructeur Vehicle manufacture instruction	Istruzioni del produttore del carrello Autorūpņicas instrukcija Lastebilproducentens anvisning Instrukcja producenta pojazdu Lastvagnstillverkarens anvisning	
	Fahrtrichtung Kørselsretning Ajosuunta	Sens de conduite Direction of travel Senso di marcia	Kustības virziens Kjøreretning Kierunek jazdy Färdriktning

## **Allgemein**

Die Montage darf nur von ausgebildetem und kompetentem Fachpersonal durchgeführt werden und muß in einer befugten Werkstatt erfolgen, die über erforderliche Werkzeuge und Ausrüstungen verfügt, und in der Zugänglichkeit und Sicherheit gegeben sind. Alle Teile vor der Montage identifizieren. Anweisungen befolgen.

Empfohlene Einstellungen nicht ändern. Übergeben Sie dem Kunden alle Anweisungen und Instruktionen zur Aufbewahrung im Fahrzeug für künftige Service- und Wartungsarbeiten.

 Befolgen Sie die Anweisungen des LKW-Herstellers

## **Generelt**

Monteringen skal foretages af uddannet og kompetent personale og ske på autoriseret værksted, der råder over det nødvendige værktøj og udstyr, og hvor der sikres tilgængelighed og sikkerhed. Kontroller at alle dele er til stede inden montering. Følg anvisningerne.

Anbefalede indstillinger må ikke ændres. Giv kunden alle anvisninger og instruktioner, så de kan lægges i bilen til brug ved fremtidig service og vedligeholdelse.

 Følg lastbilfabrikantens anvisninger



## Yleistä

Laitteisto on asennettava valtuutetussa korjaamossa, jonka koulutetulla ja ammattitaitoisella henkilökunnalla on käytössään tarvittavat työkalut ja varusteet ja jossa on turvalliset työskentelyolot. Tunnista kaikki osat ennen asennusta. Noudata ohjeita.

Älä muuta suositeltuja säätöjä. Luovuta kaikki ohjeet asiakkaalle säilytettäväksi autossa tulevia huoltoja ja kunnossapitoa varten.



Noudata ajoneuvon valmistajan ohjeita



## Généralités

Le montage doit être effectué par des personnes possédant la compétence et la formation requises, dans un atelier autorisé disposant des outils et équipements nécessaires et où l'accessibilité et la sécurité peuvent être assurées. Identifier tous les composants avant de procéder au montage. Suivre les instructions.

Ne pas modifier les réglages recommandés. Toutes les informations et toutes les instructions doivent être remises au client afin d'être conservées dans le véhicule et utilisées pour les opérations d'entretien futures.



Se conformer également aux instructions du constructeur du camion



## General

Installation work should be carried out by trained and skilled staff. It should be performed at an authorised workshop where the required tools and equipment are available and where provisions can be made for accessibility and safety. Identify all components prior to installation. Follow the instructions.

Do not alter the recommended settings. Give the customer all directives and instructions so that these can be kept in the vehicle for future service and maintenance.



Follow the instructions of the vehicle manufacturer



## Generalità

Il montaggio deve essere effettuato da personale competente e dotato della formazione richiesta, in una officina autorizzata, in possesso delle necessarie attrezzature e dove accessibilità e sicurezza possano essere garantite. Identificare tutti i componenti prima di procedere al montaggio. Seguire le istruzioni.

Non modificarne le raccomandazioni. Tutte le informazioni e tutte le istruzioni devono essere trasmesse al cliente e conservate a corredo del veicolo per essere utilizzate nelle operazioni di successiva manutenzione.



Attenersi altresì alle istruzioni del costruttore del veicolo.

**LV**

## Vispārēji norādījumi

Uzstādīšanas darbi jāveic trenētām un apmācītam personālam. Tie jāizpilda autorizētā darbnīcā, kur ir pieejami nepieciešamie darbarīki un aprīkojums un kur ir nepieciešamie nosacījumi, lai nodrošinātu piekļuvi un drošību. Pirms montāžas identificējiet visas detaļas. Sekojiet norādījumiem. Neizmainiet ieteiktos iestatījumus. Visus norādījumus un instrukcijas izsniedziet klientam, lai tās tiktu uzglabātas automobilī un būtu pieejamas servisa un apkopes gadījumos.



Ievērojiet automašīnas izgatavotāja instrukcijas.

**NO**

## Generelt

Monteringen skal utføres av kompetent personell med nød-vendig opplæring, og skal skje på autorisert verksted hvor nødvendig verktøy og utstyr er tilgjengelig og sikkerheten kan ivaretas. Identifiser alle deler før montering. Følg anvisningene.

Ikke foreta endringer av anbefalte innstillinger. Overlever alle anvisninger og instruksjoner til kunden for oppbevaring i kjøretøyet for fremtidig service og vedlikehold.



Følg lastebilprodusentens anvisninger

**PL**

## Informacje ogólne

Montaż powinien być wykonywany wyłącznie przez przeszkolonych i kompetentnych pracowników. Powinien być wykonany w autoryzowanym punkcie obsługi technicznej, gdzie znajdują się wymagane narzędzia i wyposażenie oraz gdzie może być zapewniony odpowiedni dostęp i bezpieczeństwo. Zapoznaj się z poszczególnymi częściami przed przystąpieniem do montażu. Stosuj się do instrukcji. Nie zmieniaj zalecanych ustawień. Wszystkie wskazówki i instrukcje należy przekazać klientowi w celu przechowywania ich w pojeździe i wykorzystywania przy okazji przyszłych czynności serwisowych i konserwacyjnych.



Postępuj zgodnie z instrukcją producenta pojazdu.

**SE**

## Allmänt

Monteringen skall utföras av utbildad och kompetent personal och ske på auktoriserad verkstad där erforderliga verktyg och utrustning finns och där åtkomlighet och säkerhet kan tillgodoses. Identifiera alla delar före montering. Följ anvisningarna.

Ändra ej rekommenderade inställningar. Lämna alla anvisningar och instruktioner till kunden att förvaras i fordonet för framtida service och underhåll.



Följ lastvagnstillverkarens anvisningar

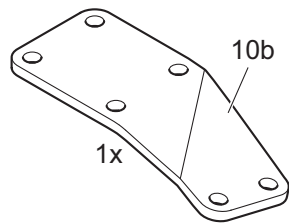
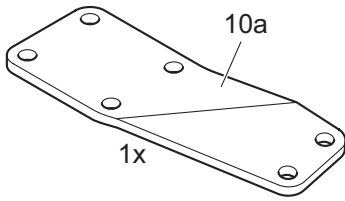
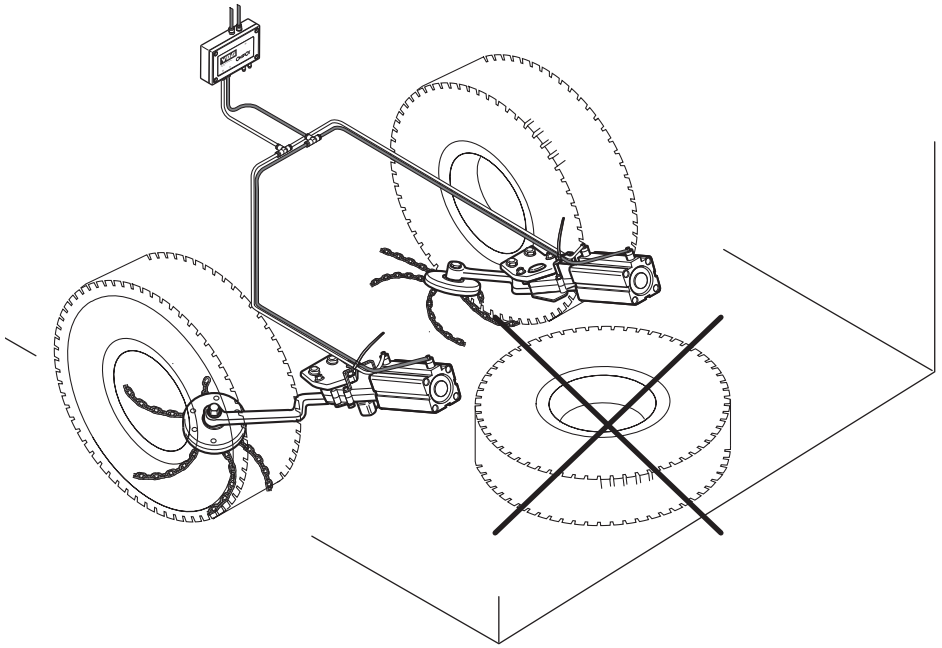

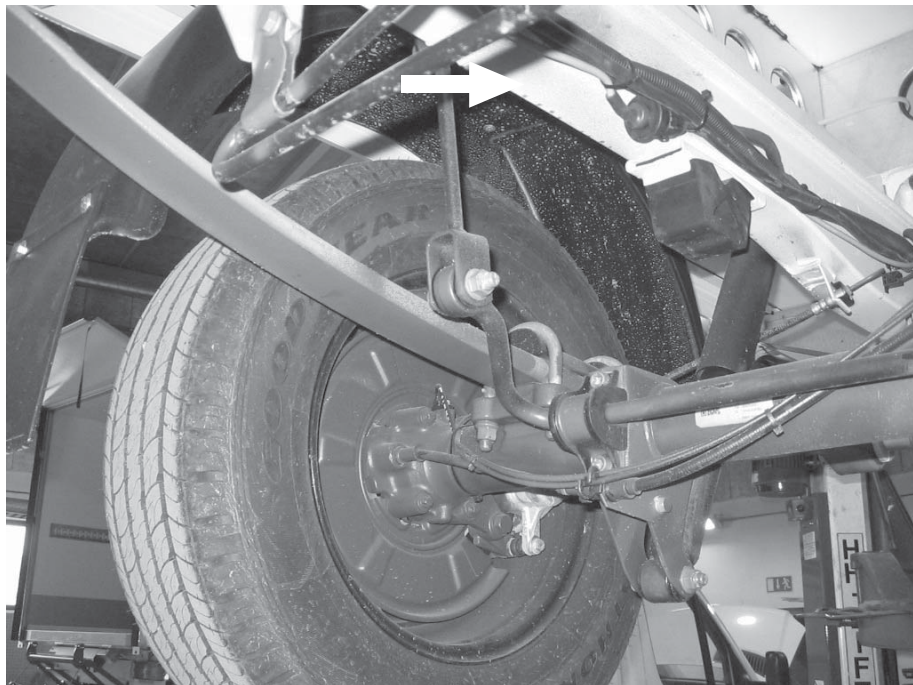

1a.

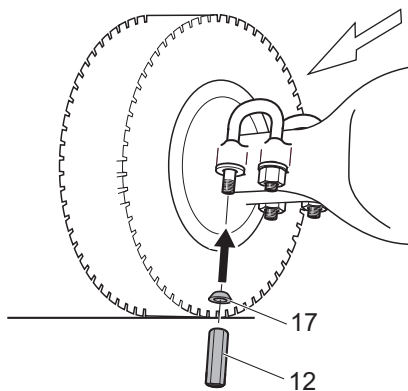
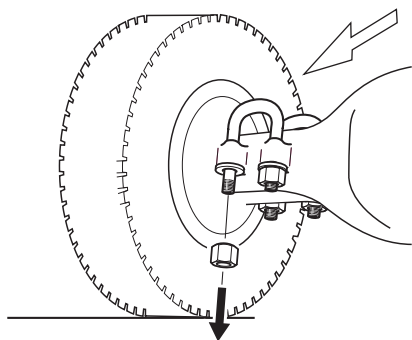

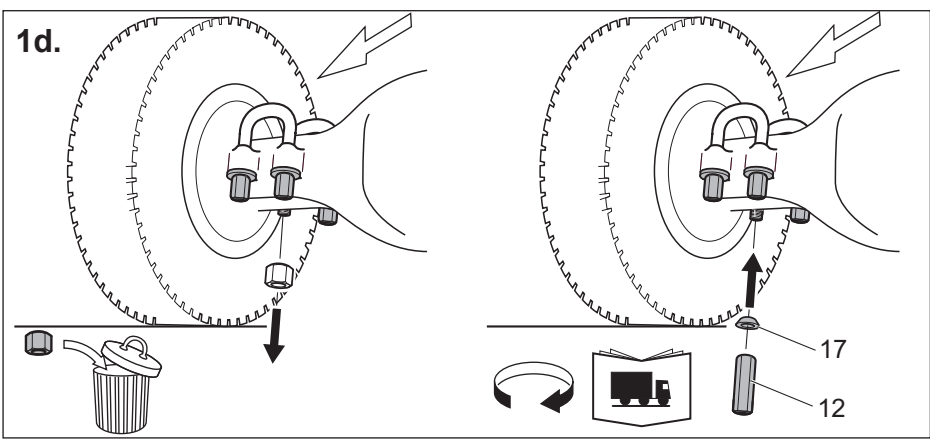
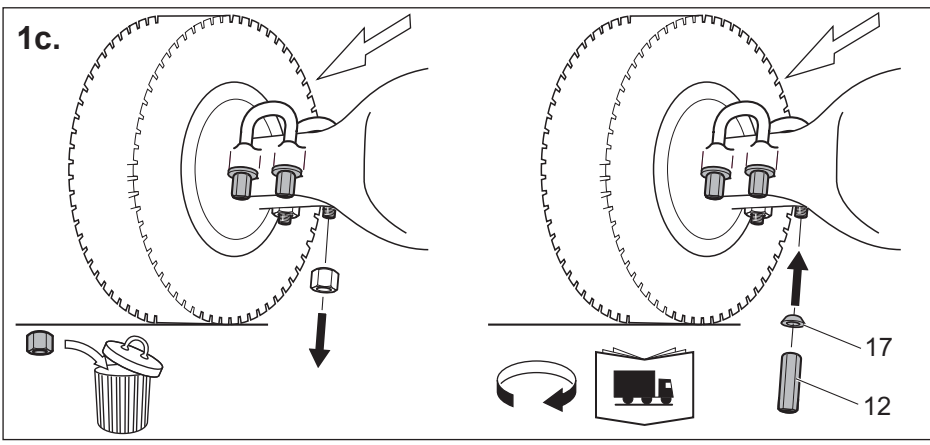
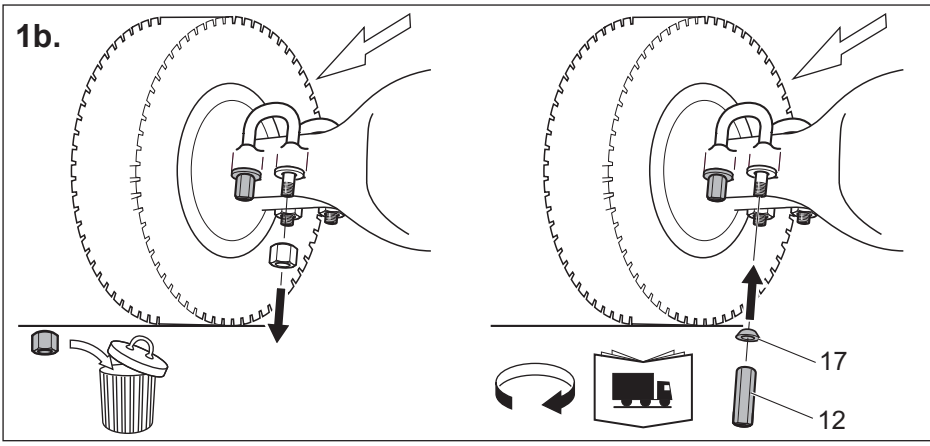

2.

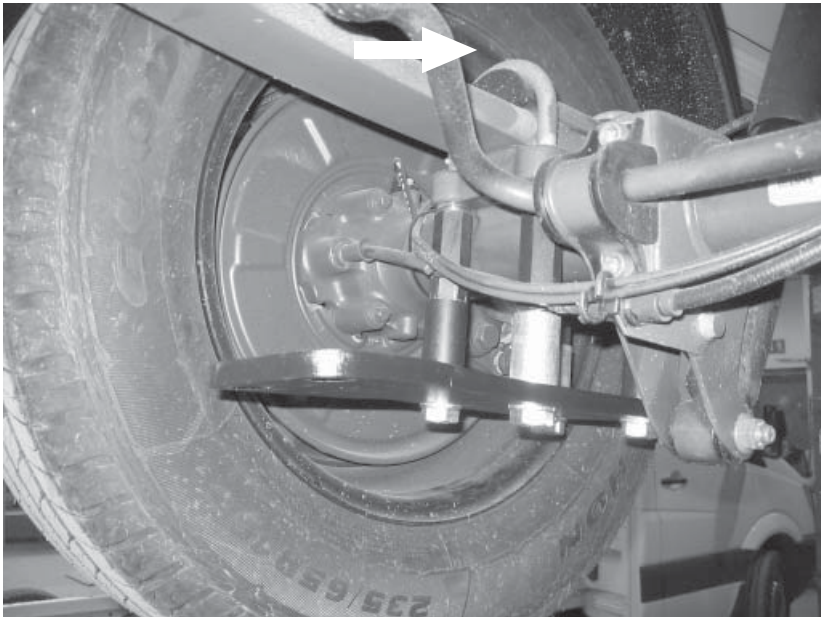
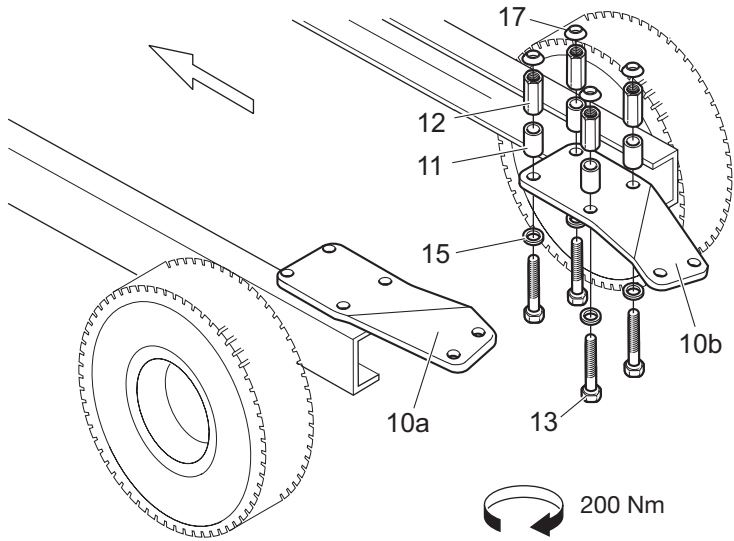



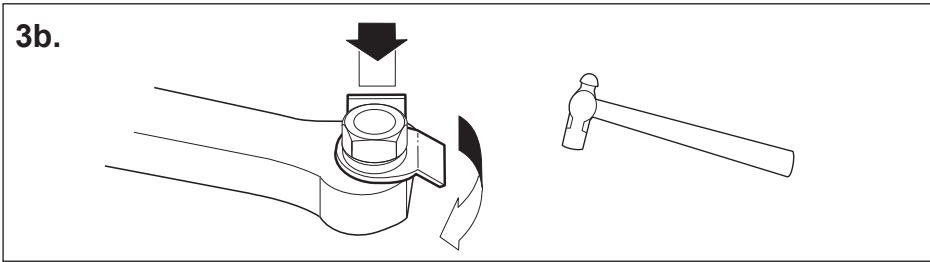
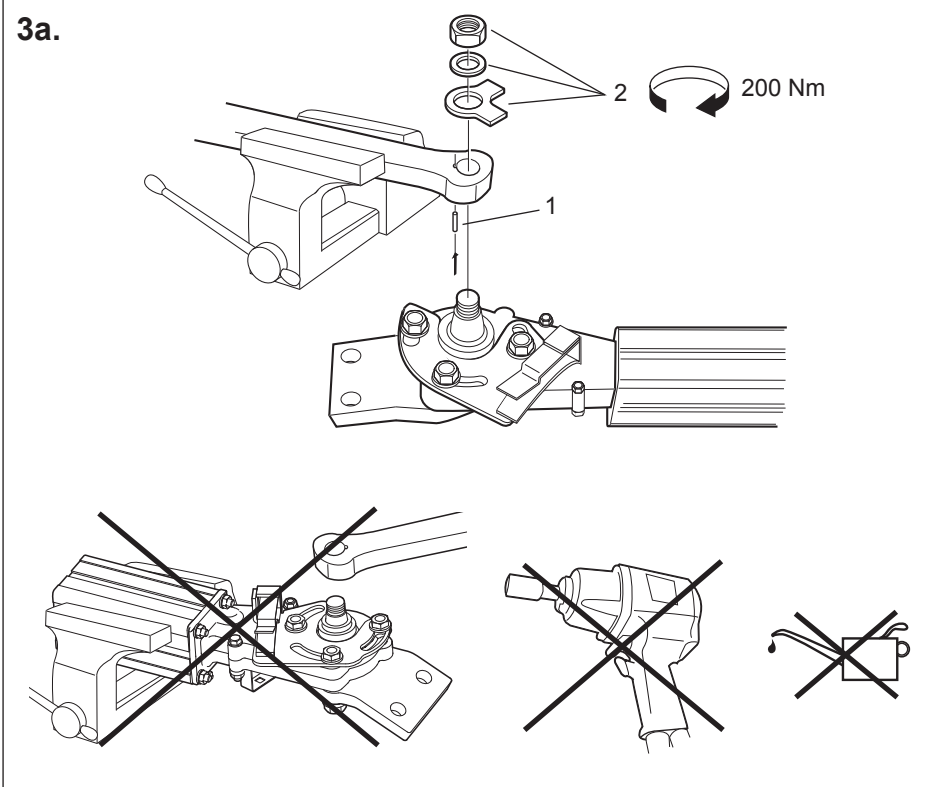
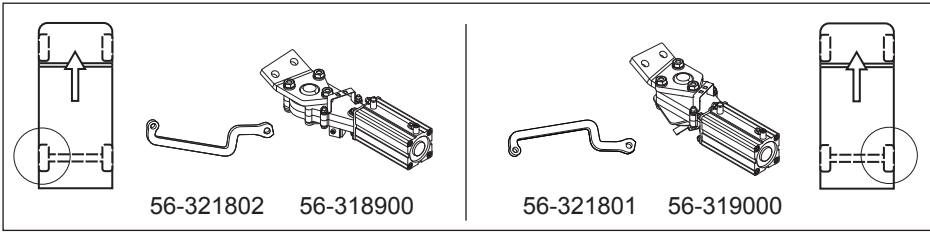

4.

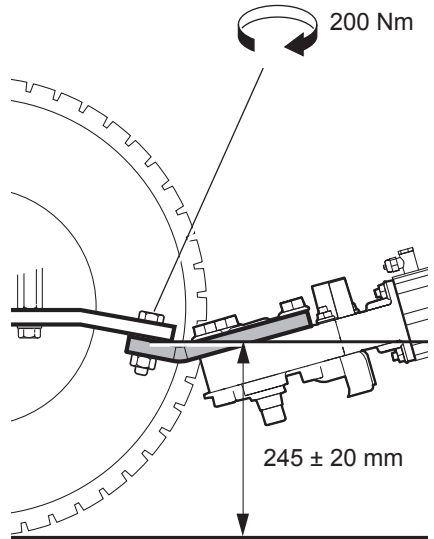
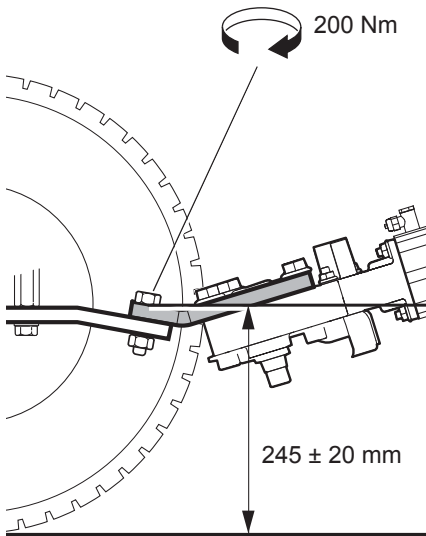
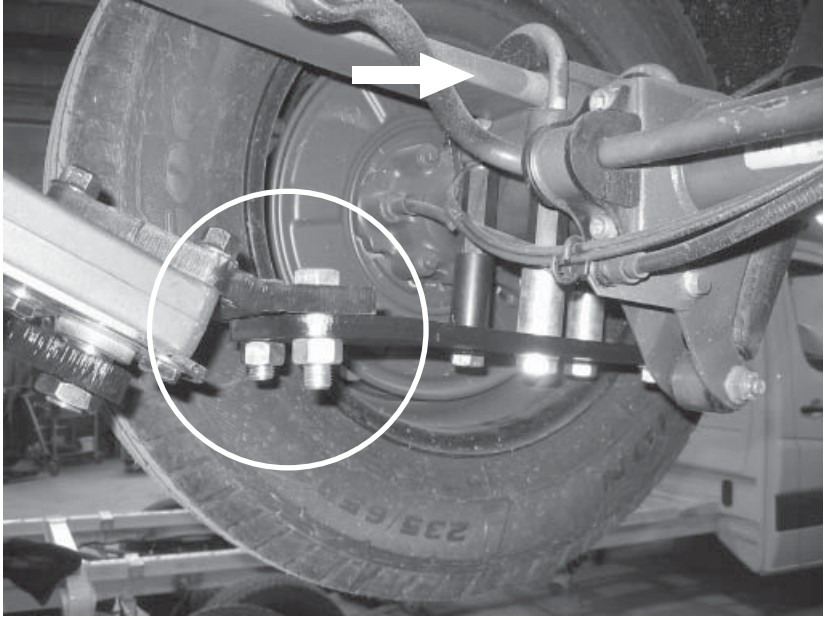

---

5.

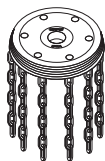

38-155900

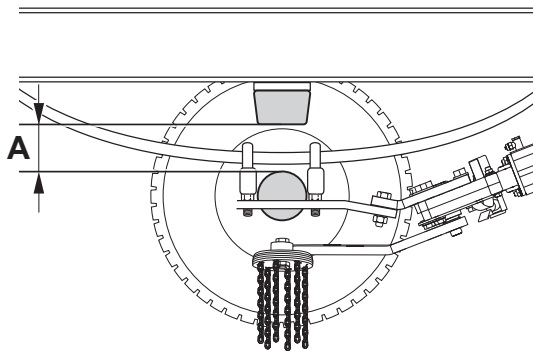
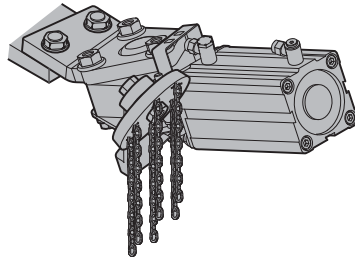

6.

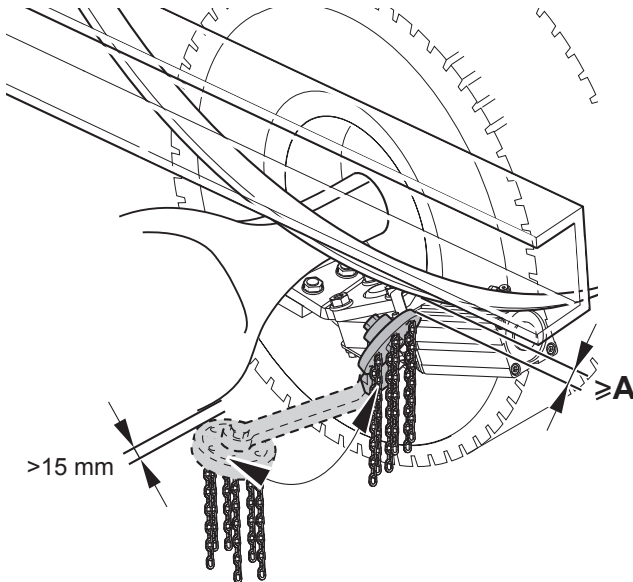

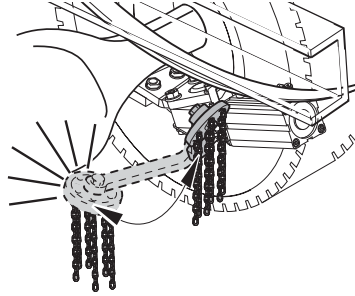

7.

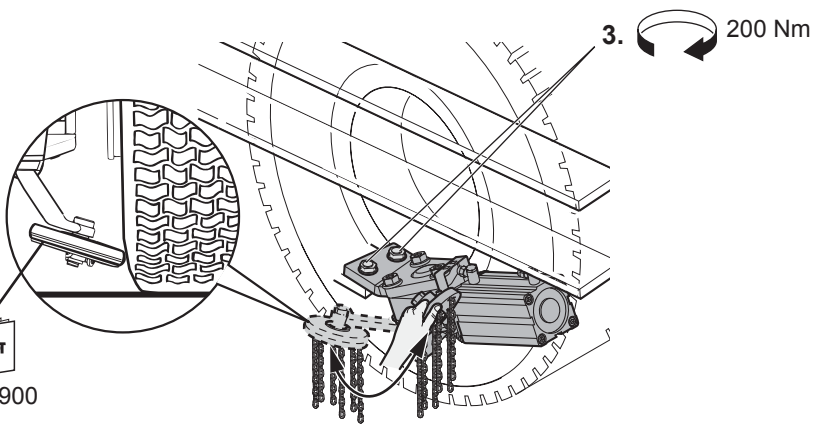
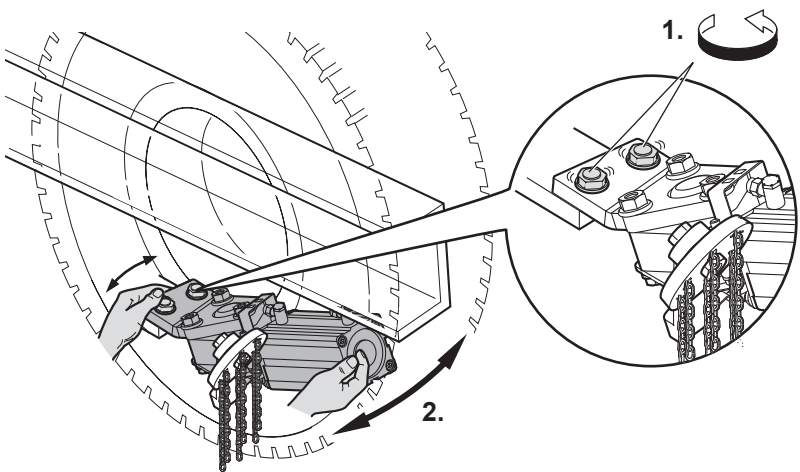

38-155900

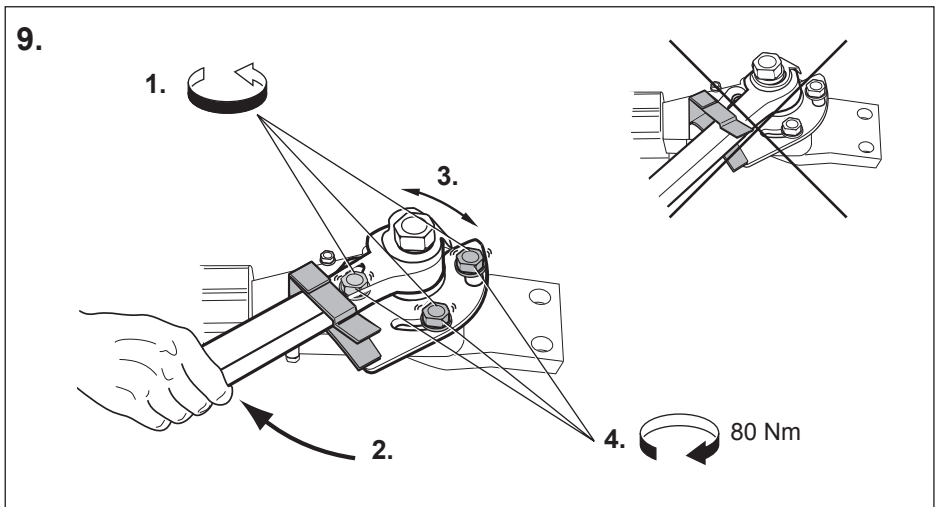
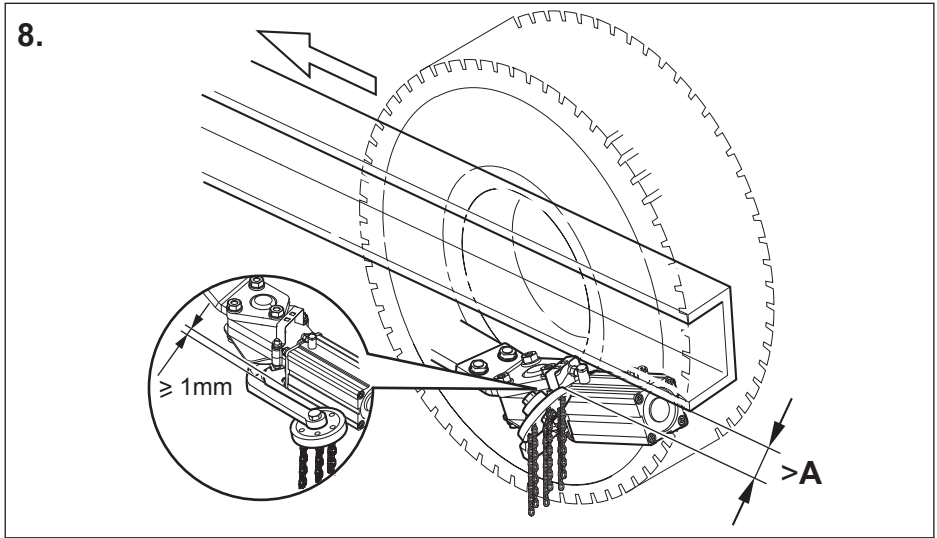
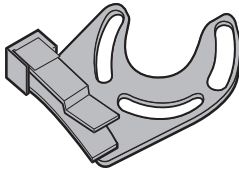

10.

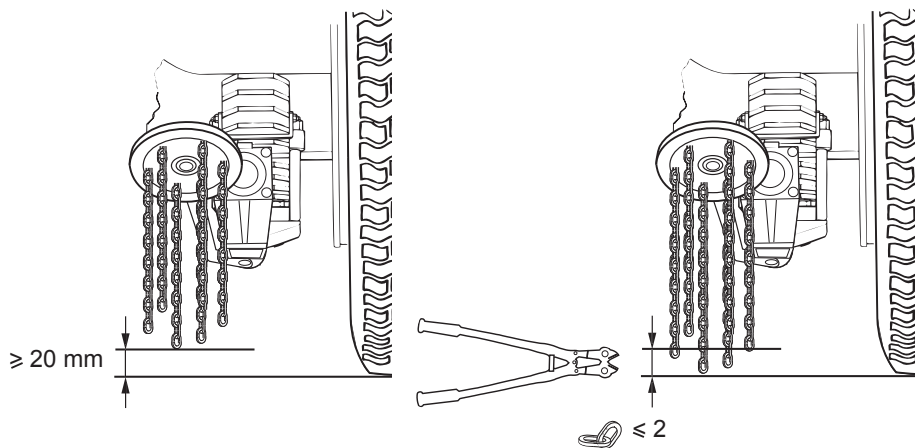

11.

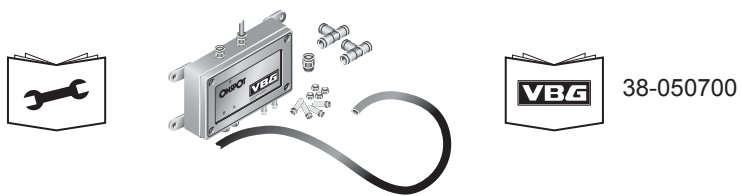

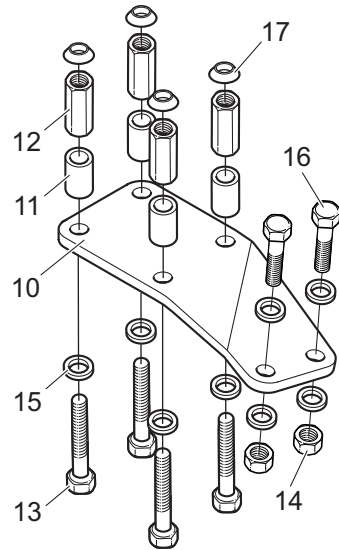
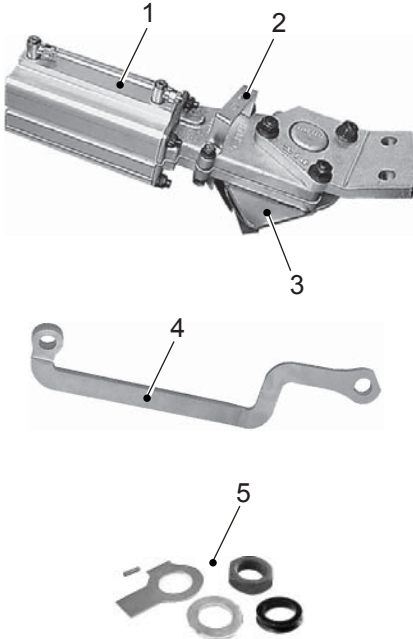
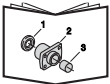

**DE 56-243000 56-322001**

Pos	Art.-nr	Bezeichnung	Anzahl	Pos	Det.nr	Bezeichnung	Anzahl
<b>Onspotaggregat und Arm</b>				<b>Adapterplatten</b>			
1	56-320501	Onspot-Aggregat rechts (Stanznummer 56-319000)	1	10a	56-243101	Adapterplatte links	1
	56-320502	Onspot-Aggregat links (Stanznummer 56-318900)	1	10b	56-243102	Adapterplatte rechts	1
2	56-320400	Schlauchhalter	2	11	56-105112	Distanzrohr L= 50	8
3	56-320601	Stopper rechts, komplett (Stanznummer 56-318803)	1	12	56-109808	Doppelmuttern	8
	56-320602	Stopper links, komplett (Stanznummer 56-318804)	1	13	35-032800	Schraube M16x80	8
4	56-321017	Arm rechts inkl. pos. 5 (Stanznummer 56-321801)	1	14	36-013100	Mutter M16	4
	56-321018	Arm links inkl. pos. 5 (Stanznummer 56-321802)	1	15	37-000700	Scheibe 17x30x3	16
5	56-320700	Befestigungsteile für Arm	2	16	35-011500	Schraube M16x50	4
				17	56-243400	Radienscheibe	8

Die VBG GROUP TRUCK EQUIPMENT AB behält sich das Recht auf Konstruktionsänderungen vor.



DK

**56-243000 56-322001**

Pos	Art..nr.	Betegnelse	Antal	Pos	Art.nr.	Betegnelse	Antal
<b>Onspotaggregat og arm</b>				<b>Konsol</b>			
1	56-320501	Onspotaggregat højre (ihugget nr. 56-319000)	1	10a	56-243101	Konsol venstre	1
	56-320502	Onspotaggregat venstre (ihugget nr. 56-318900)	1	10b	56-243102	Konsol højre	1
2	56-320400	Slangeholder	2	11	56-105112	Afstandsstykke L= 50	8
3	56-320601	Stop højre, komplet (ihugget nr. 56-318803)	1	12	56-109808	Dobbeltmøtrik	8
	56-320602	Stop venstre, komplet (ihugget nr. 56-318804)	1	13	35-032800	Bolt M16x80	8
4	56-321017	Arm højre inkl. pos. 5 (ihugget nr. 56-321801)	1	14	36-013100	Møtrik M16	4
	56-321018	Arm venstre inkl. pos. 5 (ihugget nr. 56-321802)	1	15	37-000700	Skive 17x30x3	16
5	56-320700	Monteringsdele til arm	2	16	35-011500	Bolt M16x50	4
				17	56-243400	Koniskskive	8

VBG GROUP TRUCK EQUIPMENT AB forbeholder sig retten til konstruktionsændringer.

FI

**56-243000 56-320001**

Pos	Tuote no	Nimitys	Kpl	Pos	Tuote no	Nimitys	Kpl
<b>Onspot-laite ja varsi</b>				<b>Autokiinnike</b>			
1	56-320501	Oikea Onspot-laite (meistetty nro 56-319000)	1	10a	56-243101	Vasen autokiinnike	1
	56-320502	Vasen Onspot-laite (meistetty nro 56-318900)	1	10b	56-243102	Oikea autokiinnike	1
2	56-320400	Letkunpidin	2	11	56-105112	Väliputki L= 50	8
3	56-320601	Oikea rajoitinasennelma (meistetty nro 56-318803)	1	12	56-109808	Kaksoismutteri	8
	56-320602	Vasen rajoitinasennelma (meistetty nro 56-318804)	1	13	35-032800	Ruuvi M16x80	8
4	56-321017	Oikea varsi sis. pos. 5 (meistetty nro 56-321801)	1	14	36-013100	Mutteri M16	4
	56-321018	Vasen varsi sis. pos. 5 (meistetty nro 56-321802)	1	15	37-000700	Aluslevy 17x30x3	16
5	56-320700	Varren asennusosat	2	16	35-011500	Ruuvi M16x50	4
				17	56-243400	Kartioaluslevy	8

VBG GROUP TRUCK EQUIPMENT AB pidättää oikeuden muuttaa rakennetta.

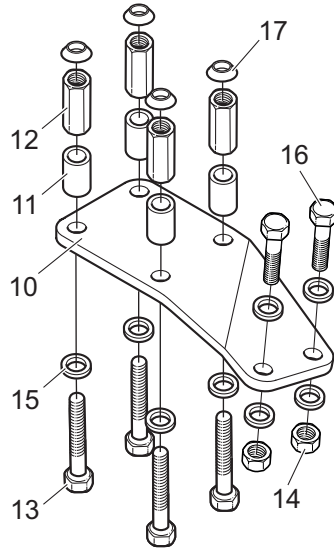
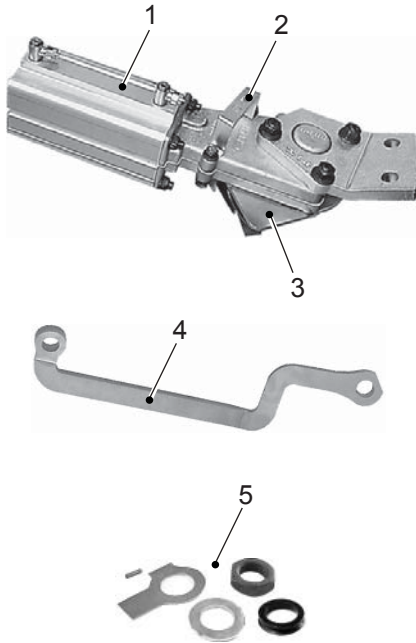

**FR 56-243000 56-322001**

Pos	N°d'art.	Désignation	Qté	Pos	N°d'art.	Désignation	Qté
<b>Groupe Onspot et bras</b>				<b>Fixation voiture</b>			
1	56-320501	Groupe Onspot droit (No. 56-319000)	1	10a	56-243101	Fixation voiture gauche	1
	56-320502	Groupe Onspot gauche (No. 56-318900)	1	10b	56-243102	Fixation voiture droit	1
2	56-320400	Support de tuyaux	2	11	56-105112	Douille d'espacement L= 50	8
3	56-320601	Manivelle d'arrêt droit complète (No. 56-318803)	1	12	56-109808	Écrou double	8
	56-320602	Manivelle d'arrêt gauche complète (No. 56-318804)	1	13	35-032800	Vis M16x80	8
4	56-321017	Bras droit, avec pos. 5 (No. 56-321801)	1	14	36-013100	Écrou M16	4
	56-321018	Bras gauche, avec pos. 5 (No. 56-321802)	1	15	37-000700	Rondelle 17x30x3	16
5	56-320700	Éléments de fixation du bras	2	16	35-011500	Vis M16x50	4
				17	56-243400	Rondelle plate	8

VBG GROUP TRUCK EQUIPMENT AB se réserve le droit de modifier ses constructions.

**GB 56-243000 56-322001**

Pos	Part no.	Description	Qty	Pos	Part no.	Description	Qty
<b>Onspot-unit and arm</b>				<b>Vehicle bracket</b>			
1	56-320501	Onspot unit right (stamped no. 56-319000)	1	10a	56-243101	Vehicle bracket left	1
	56-320502	Onspot unit left (stamped no. 56-318900)	1	10b	56-243102	Vehicle bracket right	1
2	56-320400	Hose holder	2	11	56-105112	Spacing tube L= 50	8
3	56-320601	Stop knob right, complete (stamped no. 56-318803)	1	12	56-109808	Double nut	8
	56-320602	Stop knob left, complete (stamped no. 56-318804)	1	13	35-032800	Screw M16x80	8
4	56-321017	Arm right, incl. pos. 5 (stamped no. 56-321801)	1	14	36-013100	Nut M16	4
	56-321018	Arm left, incl. pos. 5 (stamped no. 56-321802)	1	15	37-000700	Washer 17x30x3	16
5	56-320700	Arm fasteners	2	16	35-011500	Screw M16x50	4
				17	56-243400	Radius washer	8

VBG GROUP TRUCK EQUIPMENT AB reserve the right to amend or alter specifications at their

**IT 56-243000 56-322001**

Pos.	Codice	Descrizione	Q	Pos.	Codice	Descrizione	Q
<b>Unità Onspot e braccio</b>				<b>Staffe per montaggio al veicolo</b>			
1	56-320501	Unità Onspot destra (n°identificativo 56-319000)	1	10a	56-243101	Staffa sinistra	1
	56-320502	Unità Onspot sinistra (n°identificativo 56-318900)	1	10b	56-243102	Staffa destra	1
2	56-320400	Supporto del flessibile	2	11	56-105112	Distanziale L= 50	8
3	56-320601	Manovella d'arresto destra, completa (n°identificativo 56-318803)	1	12	56-109808	Dado doppio	8
	56-320602	Manovella d'arresto sinistra, completa (n°identificativo 56-318804)	1	13	35-032800	Vite M16x80	8
4	56-321017	Braccio destro, incl. pos. 5 (n°identificativo 56-321801)	1	14	36-013100	Dado M16	4
	56-321018	Braccio sinistro, incl. pos. 5 (n°identificativo 56-321802)	1	15	37-000700	Rondella 17x30x3	16
5	56-320700	Elementi di fissaggio del braccio	2	16	35-011500	Vite M16x50	4
				17	56-243400	Rondella radiale	8

VBG GROUP TRUCK EQUIPMENT AB si riserva il diritto di modifica senza preavviso.

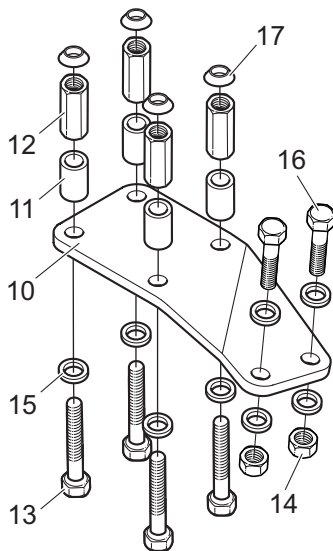
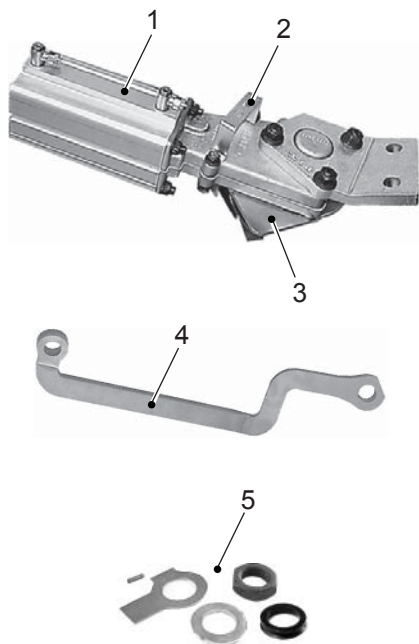

**LV 56-243000 56-322001**

Pozīcija	Det.nr.	Nosaukums	Skaitis	Pozīcija	Det.nr.	Nosaukums	Skaitis
		<b>OnSpot agregāts un svira</b>				<b>Automašīnas kronšteins</b>	
1	56-320501	OnSpot agregāts, labais (marķējuma № 56-319000)	1	10a	56-243101	Automašīnas kronšteins, kreisais	1
	56-320502	OnSpot agregāts, kreisais (marķējuma № 56-318900)	1	10b	56-243102	Automašīnas kronšteins, labais	1
2	56-320400	Šļūtenes turētājs	2	11	56-105112	Spraišļa caurule L= 50	8
3	56-320601	Izslēgšanas poga, labā, komplekts,	1	12	56-109808	Dubultuzgrieznis	8
	56-320602	Izslēgšanas poga, kreisā, komplekts,	1	13	35-032800	Skrūve M16x80	8
		(marķējuma № 56-318803)		14	36-013100	Uzgrieznis M16	4
4	56-321017	Svira, labā, iesk. poz. 5 (marķējuma № 56-321801)	1	15	37-000700	Paplāksne 17x30x3	16
	56-321018	Svira, kreisā, iesk. poz. 5 (marķējuma № 56-321802)	1	16	35-011500	Skrūve M16x50	4
5	56-320700	Sviru stiprinājumi	2	17	56-243400	Konusa paplāksne	8

VBG GROUP TRUCK EQUIPMENT AB saglabā tiesības izdarīt izmaiņas izstrādājumu konstrukcijās.

**NO 56-243000 56-322001**

Pos	Art.nr	Navn	Antall	Pos	Art.nr	Navn	Antall
<b>Onspotaggregat og arm</b>				<b>Bilfeste</b>			
1	56-320501	Onspot-aggregat høyre (identifikationsnr 56-319000)	1	10a	56-243101	Bilfeste venstre	1
	56-320502	Onspot-aggregat venstre (identifikationsnr 56-318900)	1	10b	56-243102	Bilfeste høyre	1
2	56-320400	Slangeholder	2	11	56-105112	Avstandsrør L= 50	8
3	56-320601	Stopperatt høyre, komplett (identifikationsnr 56-318803)	1	12	56-109808	Dobbeltmutter	8
	56-320602	Stopperatt venstre, komplett (identifikationsnr 56-318804)	1	13	35-032800	Skrue M16x80	8
4	56-321017	Arm høyre inkl. pos. 5 (identifikationsnr 56-321801)	1	14	36-013100	Mutter M16	4
	56-321018	Arm venstre inkl. pos. 5 (identifikationsnr 56-321802)	1	15	37-000700	Skive 17x30x3	16
5	56-320700	Festedetaljer for arm	2	16	35-011500	Skrue M16x50	4
				17	56-243400	Radiebrikke	8

VBG GROUP TRUCK EQUIPMENT AB forbeholder seg retten til konstruksjonsendringer.

**PL 56-243000 56-322001**

Poz.	Nr części	Nazwa	Ilość	Poz.	Nr części	Nazwa	Ilość
<b>Urządzenie Onspot i ramię</b>				<b>Zamocowanie do pojazdu</b>			
1	56-320501	Urządzenie Onspot strona prawa (wybity numer 56-319000)	1	10a	56-243101	Zamocowanie do pojazdu, lewe	1
	56-320502	Urządzenie Onspot strona lewa (wybity numer 56-318900)	1	10b	56-243102	Zamocowanie do pojazdu, prawe	1
2	56-320400	Uchwyt przewodu giętkiego	2	11	56-105112	Tuleja odległościowa L= 50	8
3	56-320601	Pokrętło oporowe prawo, komplet (wybity numer 56-318803)	1	12	56-109808	Nakrętka podwójna	8
	56-320602	Pokrętło oporowe lewe, komplet (wybity numer 56-318804)	1	13	35-032800	Śruba M16x80	8
4	56-321017	Ramię prawo, włącznie z poz. 5 (wybity numer 56-321801)	1	14	36-013100	Nakrętka M16	4
	56-321018	Ramię lewe, włącznie z poz. 5 (wybity numer 56-321802)	1	15	37-000700	Podkładka 17x30x3	16
5	56-320700	Elementy mocujące ramienia	2	16	35-011500	Śruba M16x50	4
				17	56-243400	Podkładka promieniowa	8

VBG GROUP TRUCK EQUIPMENT AB zastrzega sobie prawo wprowadzania zmian produktów bez uprzedzenia.

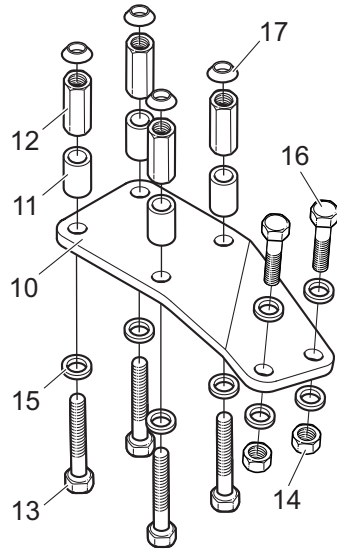
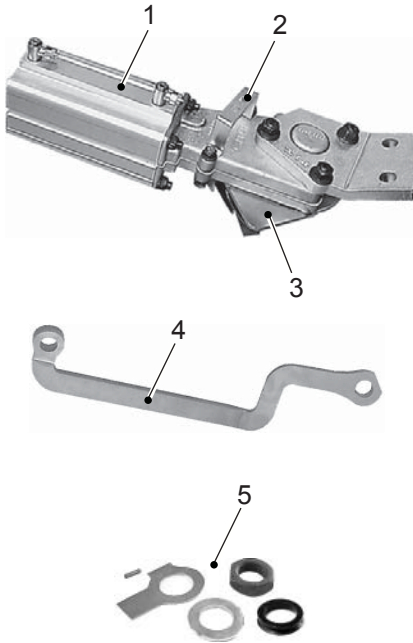

**SE 56-243000 56-322001**

Pos	Det.nr	Benämning	Antal	Pos	Det.nr	Benämning	Antal
		<b>Onspotaggregat och arm</b>				<b>Bilfäste</b>	
1	56-320501	Onspotaggregat höger (instansat nr 56-319000)	1	10a	56-243101	Bilfäste VB	1
	56-320502	Onspotaggregat vänster (instansat nr 56-318900)	1	10b	56-243102	Bilfäste HB	1
2	56-320400	Slanghållare	2	11	56-105112	Distansrör L= 50	8
3	56-320601	Stoppvred höger, komplett (instansat nr 56-318803)	1	12	56-109808	Dubbelmutter	8
	56-320602	Stoppvred vänster, komplett (instansat nr 56-318804)	1	13	35-032800	Skruv M16x80	8
4	56-321017	Arm höger inkl. pos. 5 (instansat nr 56-321801)	1	14	36-013100	Mutter M16	4
	56-321018	Arm vänster inkl. pos. 5 (instansat nr 56-321802)	1	15	37-000700	Bricka 17x30x3	16
5	56-320700	Fästdetaljer för arm	2	16	35-011500	Skruv M16x50	4
				17	56-243400	Radiebricka	8

VBG GROUP TRUCK EQUIPMENT AB förbehåller sig rätten till konstruktionsförändringar.



**AUSTRALIA**

TRANSPEC LIMITED  
P O Box 217 1 Cherry Lane  
AU - 3028 P.O LAVERTON, VIC 3028  
Tel +61 3 92 67 24 44  
Fax +61 3 93 69 48 26

**BELGIUM**

VBG GROUP SALES BENELUX NV  
Lochtemanweg 50  
B-3580 BERINGEN  
Tel +32 11 458 379  
Fax +32 11 458 378

**DENMARK**

VBG GROUP SALES A/S  
Industribuen 20-22  
DK - 5592 EJBY  
Tel +45 6446 1919  
Fax +45 6446 1088

**ESTONIA**

GOKART AS  
Peterburi tee 111  
EE-11415 TALLINN  
Tel +372 623 0622  
Faks +372 623 0621

**FINLAND**

H KRAATZ OY  
Ruukimestarintie 9  
FI - 02330 ESPOO  
Tel +358 9 8093100  
Fax +358 9 80931099

**FRANCE**

ONSPOT Sàrl  
14 Route de Sarrebruck  
FR - 57645 MONTROY-FLANVILLE  
Tel +33 3 8776 3080  
Fax +33 3 8776 1944

**GERMANY**

VBG GROUP TRUCK EQUIPMENT GMBH  
Oberschlesienstrasse 15  
DE - 47807 KREFELD  
Tel +49 2151 835 0  
Fax +49 2151 835 200

**GREAT BRITAIN**

VBG GROUP SALES LIMITED  
Unit 9 Willow Court  
West Quay Road  
Winwick Quay  
Warrington  
Cheshire WA2 8UF  
Tel +44 1925 234111  
Fax +44 1925 234222

**ICELAND**

OSAL OSKAR ANDERSSON  
Tangarhofdi 4  
IS - 110 REYKJAVIK  
Tel +354 587 6619  
Fax +354 187 7719

**IRELAND**

NEWBRIDGE METAL PRODUCTS  
Toughers Business Park  
IE - NEWHALL, Naas, Co Kildare, Eire  
Tel +353 45 431 502  
Fax +353 45 433 747

**ISRAEL**

H KLEIN & SONS LTD  
P O Box 1093  
Industrial Area-North  
IL - ASHDOD 77109  
Tel +972 8856 4330  
Fax +972 8856 4324

**ITALY**

MAGGI CANTENE S.P.A  
Via Milano 2/4  
I- 23854 Olginate  
ITALY  
Tel +39 0341 60 52 35  
Fax +39 0341 60 53 52

**JAPAN**

SHINKO BOEKI CO LTD  
Shibuya Central Bldg  
3-14 Udagawa-cho, Shibuya-ku,  
JP - TOKYO 150  
Tel +81 3 33463 0941  
Fax +81 3 33463 1707

**NETHERLANDS**

VBG GROUP SALES BENELUX NV  
Alaertslaan 12  
NL-5801 DC Venray  
Tel +31 478 514 143  
Fax +31 478 515 790

**NEW ZEALAND**

TRANSPORT SPECIALTIES LTD  
P O BOX 98-971  
NZ - S.A.M.C., Wiri, AUCKLAND  
Tel +64 9 980 7300  
Fax +64 9 980 7306

**NORWAY**

VBG GROUP SALES AS  
Postboks 94 Leirdal  
NO - 1009 OSLO  
Tel +47 23 14 16 60  
Fax +47 23 14 16 61

**POLAND**

HYVA POLSKA Sp. z o.o.  
ul. Mysłowska 68  
PL - 30718 KRAKÓW  
Tel +48 12 658 65 05  
Fax +48 12 658 44 39

**SOUTH AFRICA**

TRANSPORT TECHNOLOGY  
Greenside 2034  
ZA - 1450 JOHANNESBURG  
Tel +27 11 7810491  
Fax +27 11 7894441

**SWEDEN**

VBG GROUP TRUCK EQUIPMENT AB  
Box 1216  
SE - 462 28 VÄNERSBORG  
Tel +46 521 277700  
Fax +46 521 277795

**Branch office:**

VBG GROUP TRUCK EQUIPMENT AB  
Umestans Företagspark Hus 2  
SE - 903 47 UMEA  
Tel +46 90 271 10  
Fax +46 90 326 11

**SWITZERLAND**

AGL für LASTWAGENZUBEHÖRE  
Postfach  
CH - 6048 HORW  
Tel +41 41 340 25 25  
Fax +41 41 340 31 79

**SWITZERLAND**

AMBOFIX METALLBAU  
U. Ambühl  
Am Schachenrain 36  
CH - 4562 BIBERIST  
Tel +41 32 6 72 36 83  
Fax +41 32 67 22 267

**TANZANIA**

SUPERDOLL TRAILERS MANUFACTURE CO. LTD  
P.O Box 16541  
TZ - DAR ES SALAAM  
Tel +255 22 2860930  
Fax +255 22 2865412

---

**VBG GROUP TRUCK EQUIPMENT AB**

Herman Kreftings gata 4

Box 1216

SE-462 28 VÄNERSBORG

Tel +46 521 27 77 00

E-mail [info@vbg.se](mailto:info@vbg.se)

[www.vbg.se](http://www.vbg.se)