

Sisu 6x4 - 10x4

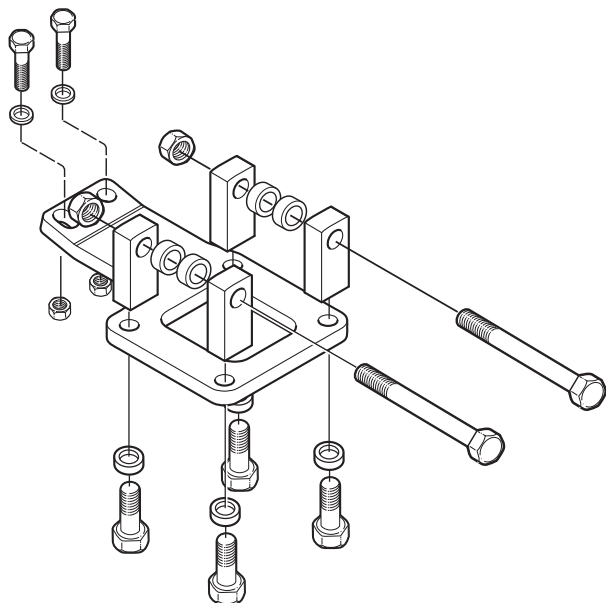

56-244100

56-320000

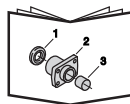

- DE** Blattfederung
- DK** Bladfjedre
- FI** Lehtijousitus
- FR** Suspension à lames
- GB** Plate suspension
- IT** Sospensioni a balestra
- LV** Plāksnes pakarināšana
- NO** Bladfjæring
- PL** Zawieszenie płytki
- SE** Bladfjädring

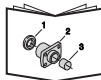

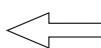
	Montageanleitung Monteringvejledning Asennusohje	Instructions de montage Mounting instruction Istruzioni di montaggio	Montāžas instrukcija Monteringsanvisning Instrukcja montażowa Monteringsanvisning
	Ersatzteilliste Reservedeliste Varaosaluettelo	Liste des pièces détachées Spare Parts List Parti di ricambio	Rezerves daļu saraksts Reservedeliste Lista czæúci zamiennych Reservdelista
	Anleitungen des Herstellers Producentens anvisning Valmistajan ohjeet	Instructions du fabricant Manufacturer's instruction Istruzioni del produttore	Ražotāja norādījumi Produsentens anvisning Wskazówki producenta Tillverkarens anvisning
	Anweisungen des LKW-Herstellers Lastbilfabrikantens anvisning Ajoneuvon valmistajan ohjeet Instruction du constructeur Vehicle manufacture instruction	Istruzioni del produttore del carrello Autorūpņicas instrukcija Lastebilproducentens anvisning Instrukcja producenta pojazdu Lastvagnstillverkarens anvisning	
	Fahrtrichtung Kørselsretning Ajosuunta	Sens de conduite Direction of travel Senso di marcia	Kustības virziens Kjøreretning Kierunek jazdy Färdriktning

## **Allgemein**

Die Montage darf nur von ausgebildetem und kompetentem Fachpersonal durchgeführt werden und muß in einer befugten Werkstatt erfolgen, die über erforderliche Werkzeuge und Ausrüstungen verfügt, und in der Zugänglichkeit und Sicherheit gegeben sind. Alle Teile vor der Montage identifizieren. Anweisungen befolgen.

Empfohlene Einstellungen nicht ändern. Übergeben Sie dem Kunden alle Anweisungen und Instruktionen zur Aufbewahrung im Fahrzeug für künftige Service- und Wartungsarbeiten.

 Befolgen Sie die Anweisungen des LKW-Herstellers

## **Generelt**

Monteringen skal foretages af uddannet og kompetent personale og ske på autoriseret værksted, der råder over det nødvendige værktøj og udstyr, og hvor der sikres tilgængelighed og sikkerhed. Kontroller at alle dele er til stede inden montering. Følg anvisningerne.

Anbefalede indstillinger må ikke ændres. Giv kunden alle anvisninger og instruktioner, så de kan lægges i bilen til brug ved fremtidig service og vedligeholdelse.

 Følg lastbilfabrikantens anvisninger



## Yleistä

Laitteisto on asennettava valtuutetussa korjaamossa, jonka koulutetulla ja ammattitaitoisella henkilökunnalla on käytössään tarvittavat työkalut ja varusteet ja jossa on turvalliset työskentelyolot. Tunnista kaikki osat ennen asennusta. Noudata ohjeita.

Älä muuta suositeltuja säätöjä. Luovuta kaikki ohjeet asiakkaalle säilytettäväksi autossa tulevia huoltoja ja kunnossapitoa varten.



Noudata ajoneuvon valmistajan ohjeita



## Généralités

Le montage doit être effectué par des personnes possédant la compétence et la formation requises, dans un atelier autorisé disposant des outils et équipements nécessaires et où l'accessibilité et la sécurité peuvent être assurées. Identifier tous les composants avant de procéder au montage. Suivre les instructions.

Ne pas modifier les réglages recommandés. Toutes les informations et toutes les instructions doivent être remises au client afin d'être conservées dans le véhicule et utilisées pour les opérations d'entretien futures.



Se conformer également aux instructions du constructeur du camion



## General

Installation work should be carried out by trained and skilled staff. It should be performed at an authorised workshop where the required tools and equipment are available and where provisions can be made for accessibility and safety. Identify all components prior to installation. Follow the instructions.

Do not alter the recommended settings. Give the customer all directives and instructions so that these can be kept in the vehicle for future service and maintenance.



Follow the instructions of the vehicle manufacturer



## Generalità

Il montaggio deve essere effettuato da personale competente e dotato della formazione richiesta, in una officina autorizzata, in possesso delle necessarie attrezzature e dove accessibilità e sicurezza possano essere garantite. Identificare tutti i componenti prima di procedere al montaggio. Seguire le istruzioni.

Non modificarne le raccomandazioni. Tutte le informazioni e tutte le istruzioni devono essere trasmesse al cliente e conservate a corredo del veicolo per essere utilizzate nelle operazioni di successiva manutenzione.



Attenersi altresì alle istruzioni del costruttore del veicolo.



## Vispārēji norādījumi

Uzstādīšanas darbi jāveic trenētām un apmācītam personālam. Tie jāizpilda autorizētā darbnīcā, kur ir pieejami nepieciešamie darbarīki un aprīkojums un kur ir nepieciešamie nosacījumi, lai nodrošinātu piekļuvi un drošību. Pirms montāžas identificējiet visas detaļas. Sekojiet norādījumiem. Neizmainiet ieteiktos iestatījumus. Visus norādījumus un instrukcijas izsniedziet klientam, lai tās tiktu uzglabātas automobilī un būtu pieejamas servisa un apkopes gadījumos.



Ievērojiet automašīnas izgatavotāja instrukcijas.



## Generelt

Monteringen skal utføres av kompetent personell med nød-vendig opplæring, og skal skje på autorisert verksted hvor nødvendig verktøy og utstyr er tilgjengelig og sikkerheten kan ivaretas. Identifiser alle deler før montering. Følg anvisningene.

Ikke foreta endringer av anbefalte innstillinger. Overlever alle anvisninger og instruksjoner til kunden for oppbevaring i kjøretøyet for fremtidig service og vedlikehold.



Følg lastebilprodusentens anvisninger



## Informacje ogólne

Montaż powinien być wykonywany wyłącznie przez przeszkolonych i kompetentnych pracowników. Powinien być wykonany w autoryzowanym punkcie obsługi technicznej, gdzie znajdują się wymagane narzędzia i wyposażenie oraz gdzie może być zapewniony odpowiedni dostęp i bezpieczeństwo. Zapoznaj się z poszczególnymi częściami przed przystąpieniem do montażu. Stosuj się do instrukcji. Nie zmieniaj zalecanych ustawień. Wszystkie wskazówki i instrukcje należy przekazać klientowi w celu przechowywania ich w pojeździe i wykorzystywania przy okazji przyszłych czynności serwisowych i konserwacyjnych.



Postępuj zgodnie z instrukcją producenta pojazdu.



## Allmänt

Monteringen skall utföras av utbildad och kompetent personal och ske på auktoriserad verkstad där erforderliga verktyg och utrustning finns och där åtkomlighet och säkerhet kan tillgodoses. Identifiera alla delar före montering. Följ anvisningarna.

Ändra ej rekommenderade inställningar. Lämna alla anvisningar och instruktioner till kunden att förvaras i fordonet för framtida service och underhåll.



Följ lastvagnstillverkarens anvisningar

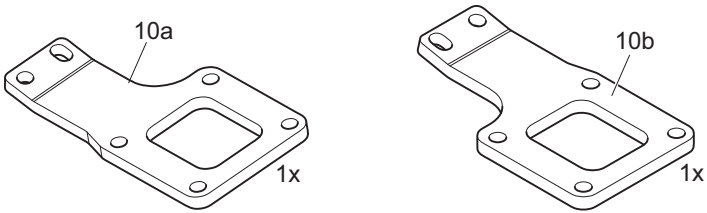
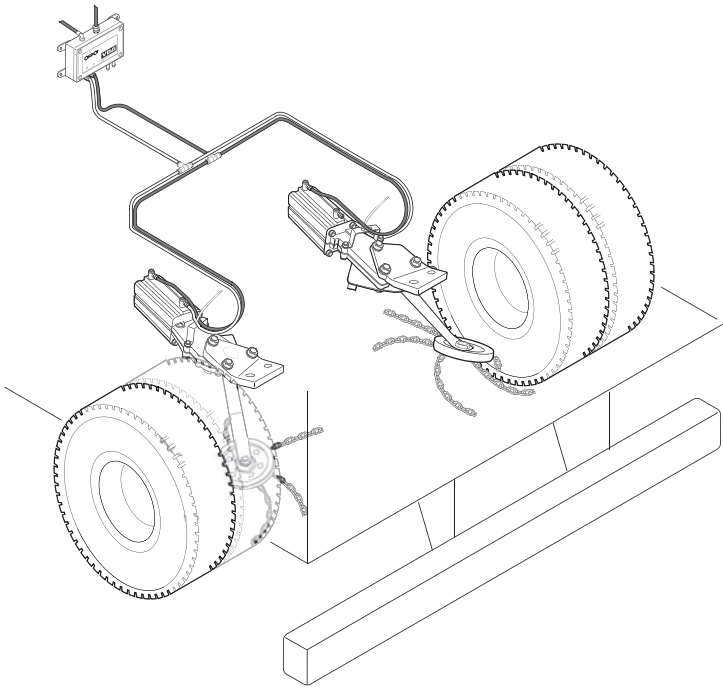

- |    |     |    |    |    |    |    |    |     |
|----|-----|----|----|----|----|----|----|-----|
| 11 | 12  | 13 | 14 | 15 | 16 | 17 | 18 | 19  |
|    |     |    |    |    |    |    |    |     |
| 8x | 12x | 8x | 8x | 4x | 2x | 4x | 4x | 16x |

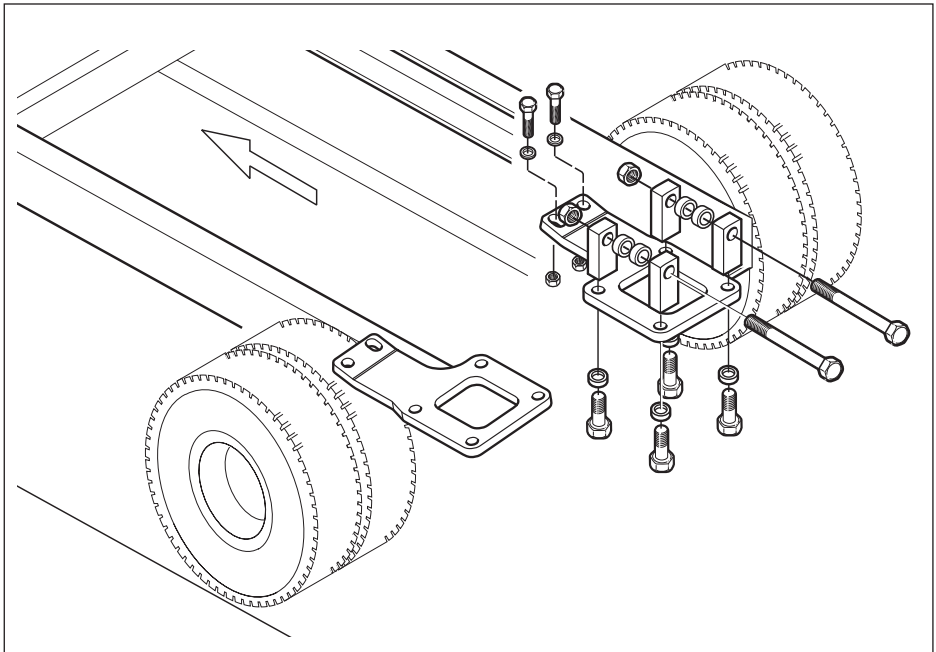
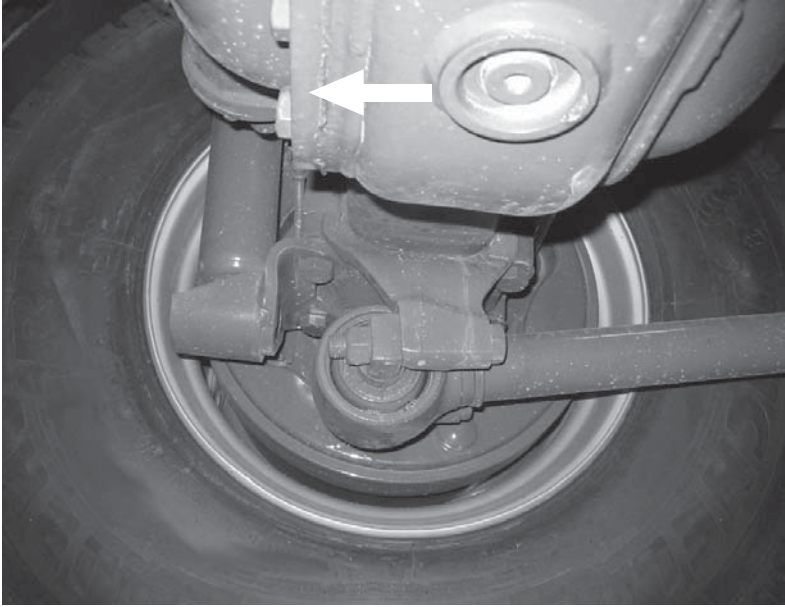

**1a.**

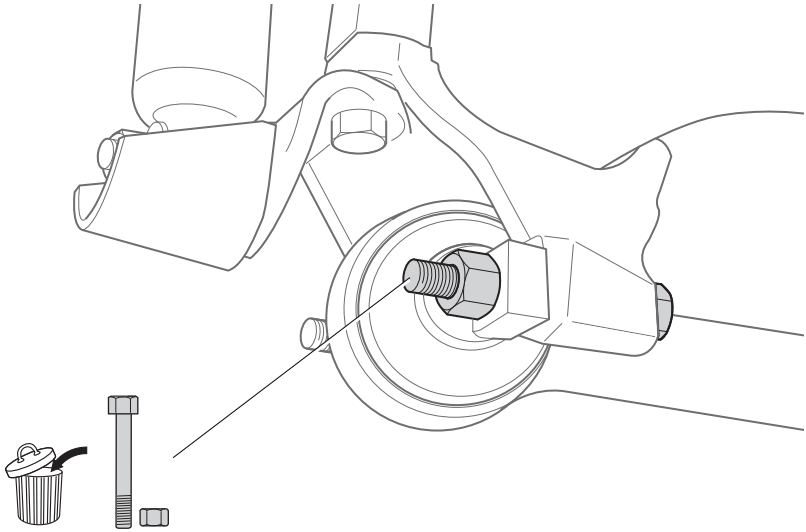

**1b.**

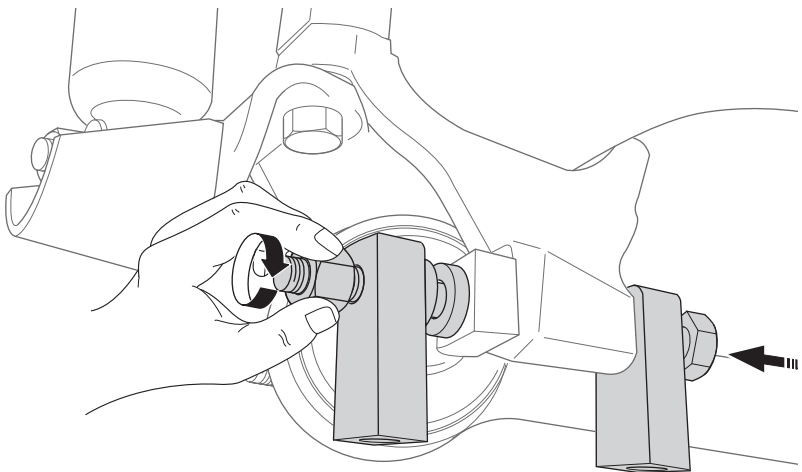

**1c.**

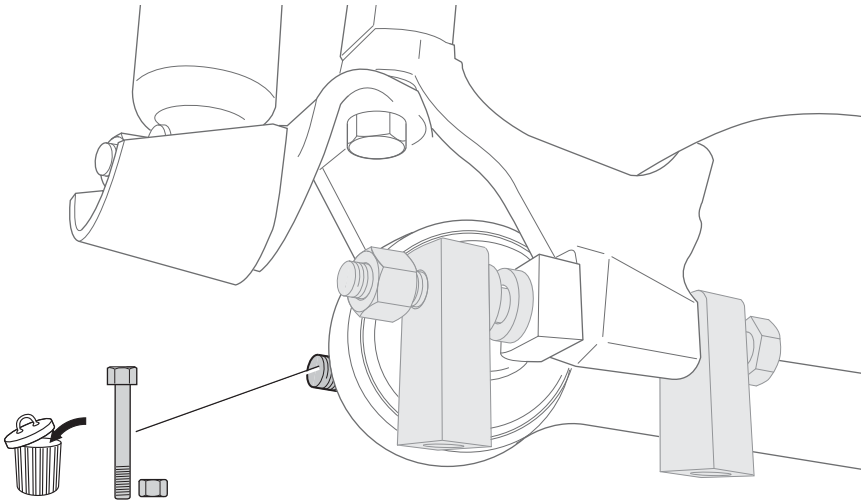

**1d.**

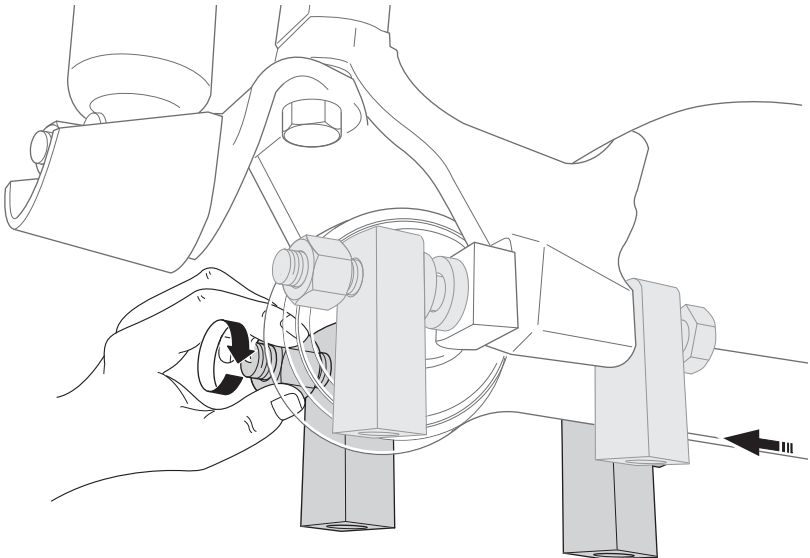



1e.

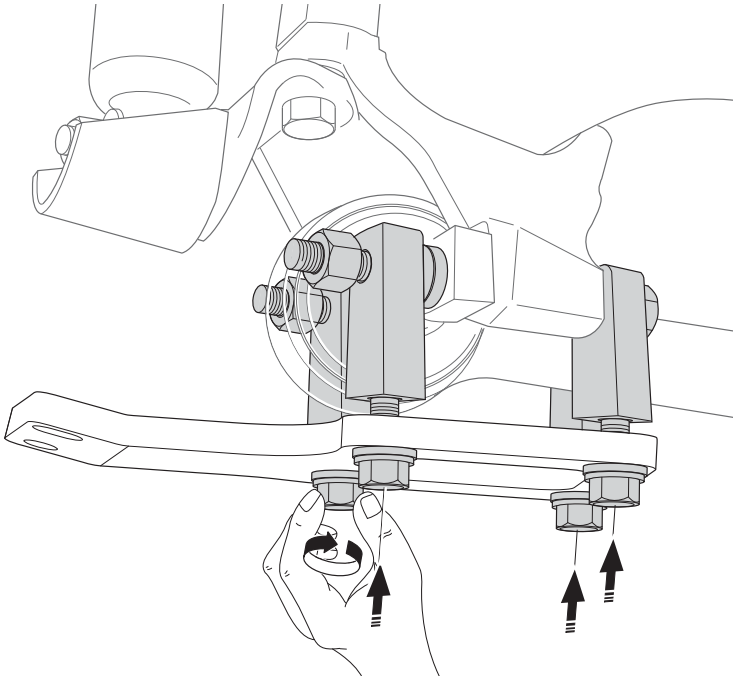

1f.

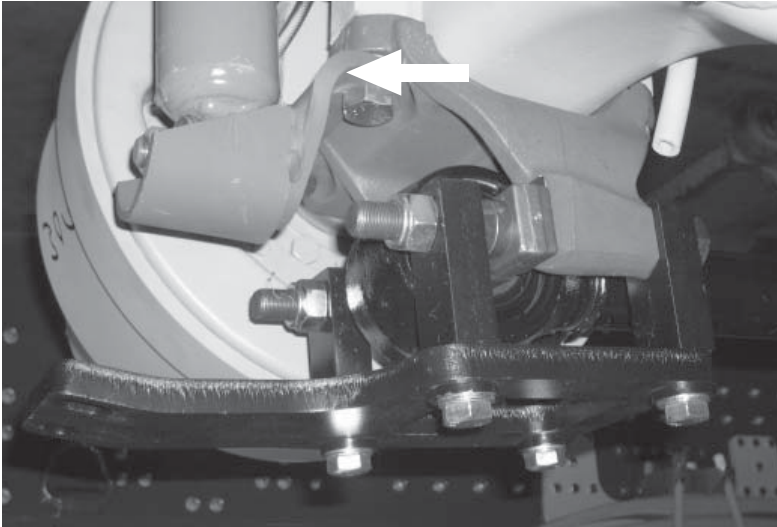
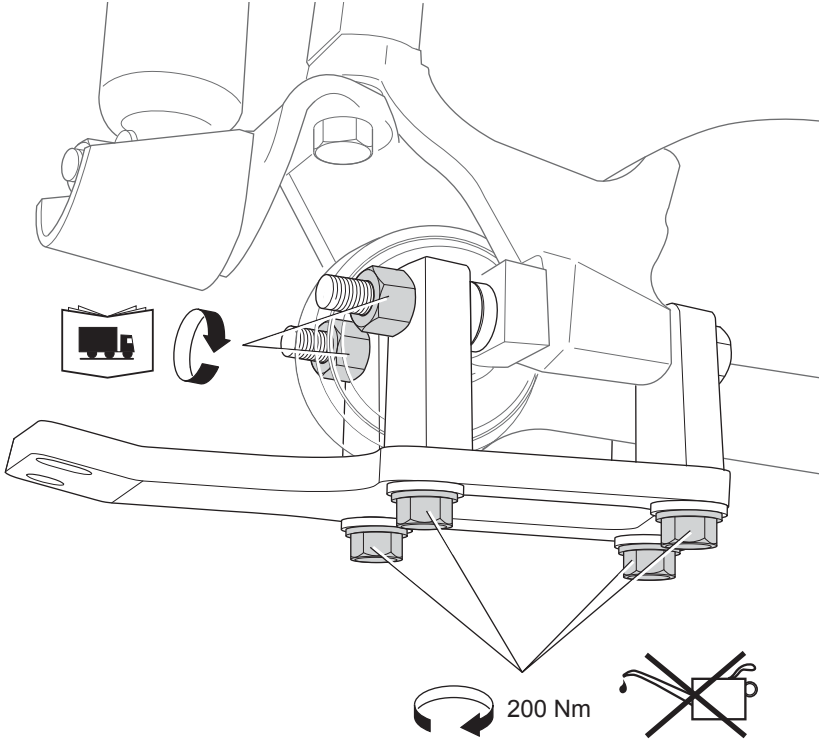

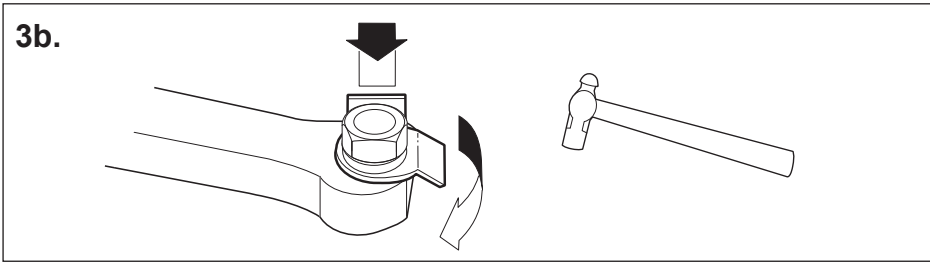
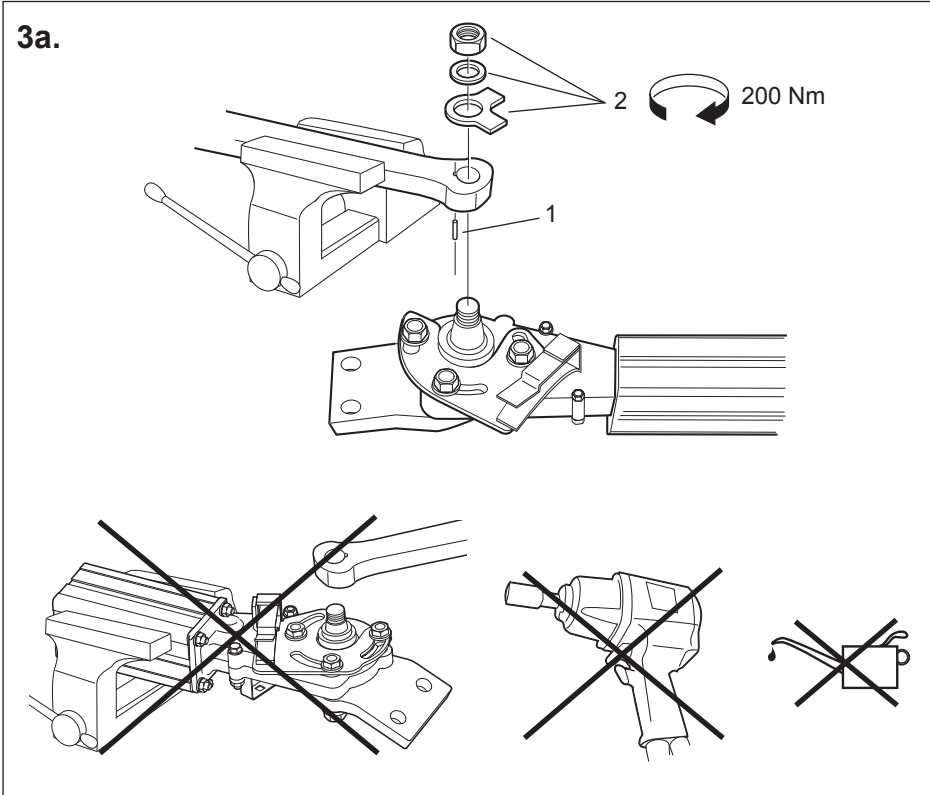
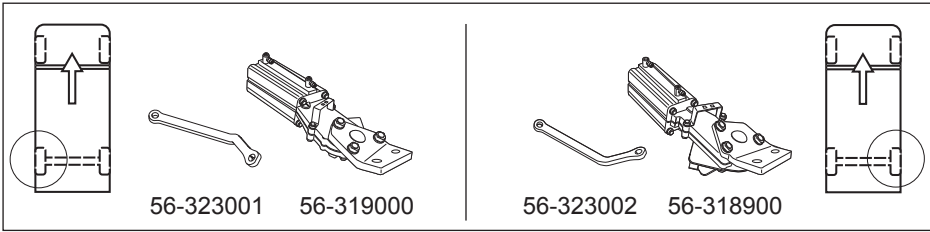

4.

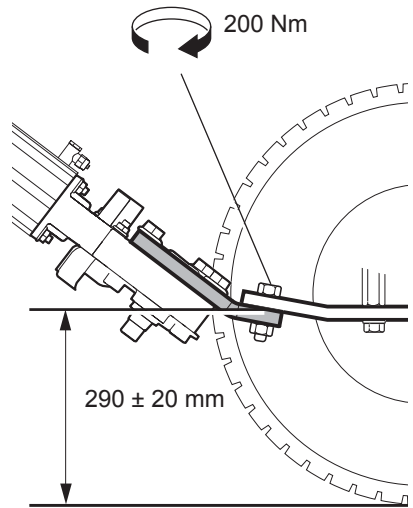
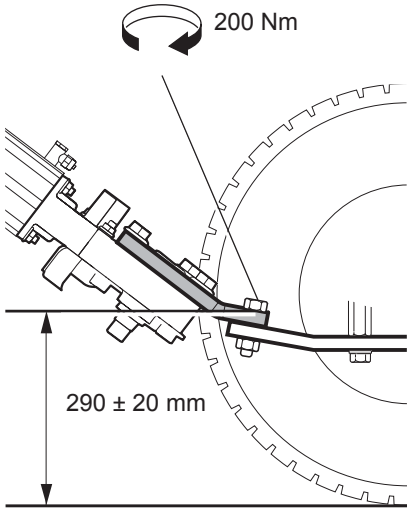
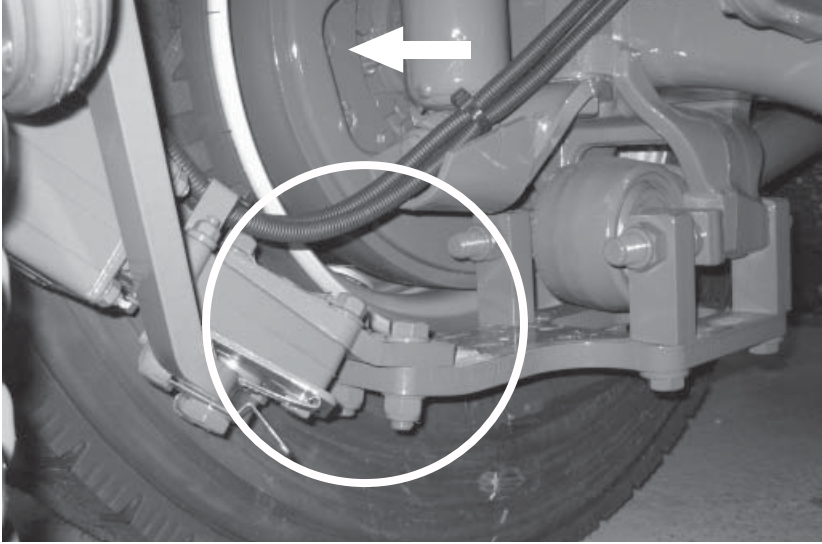

5.



38-155900

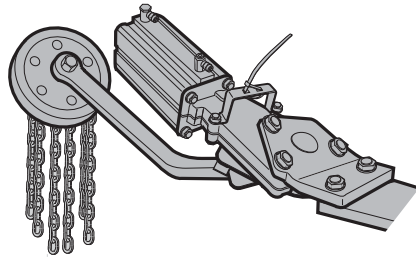

6.

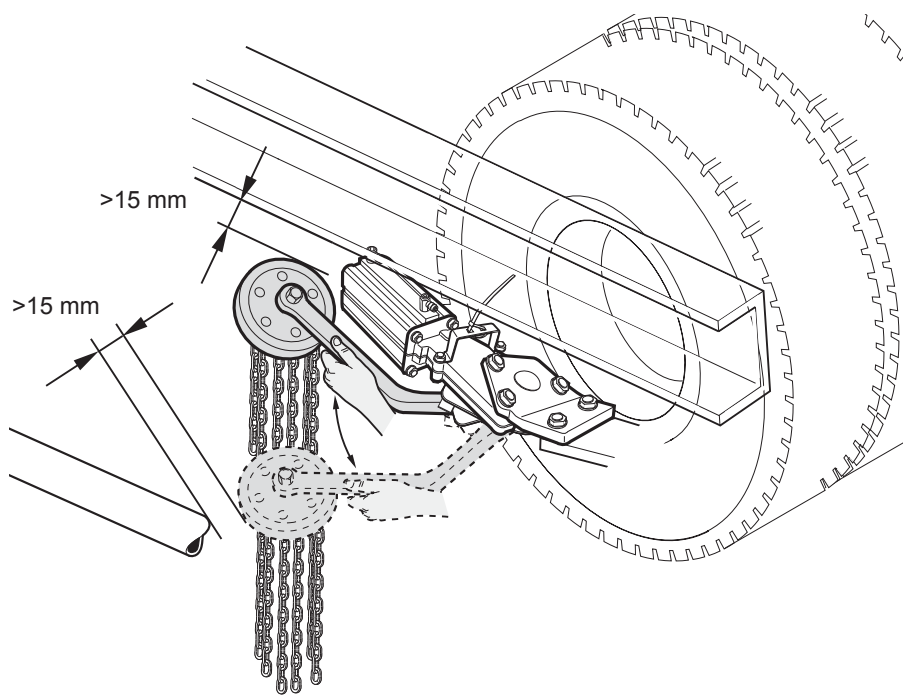

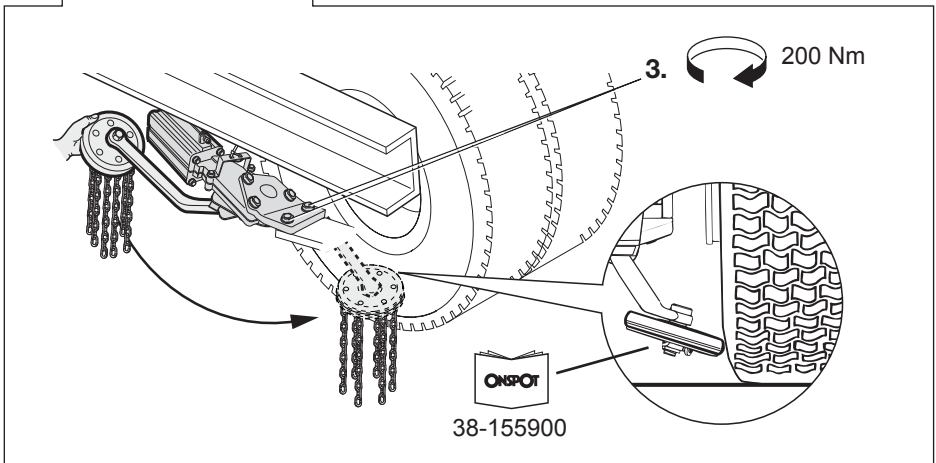
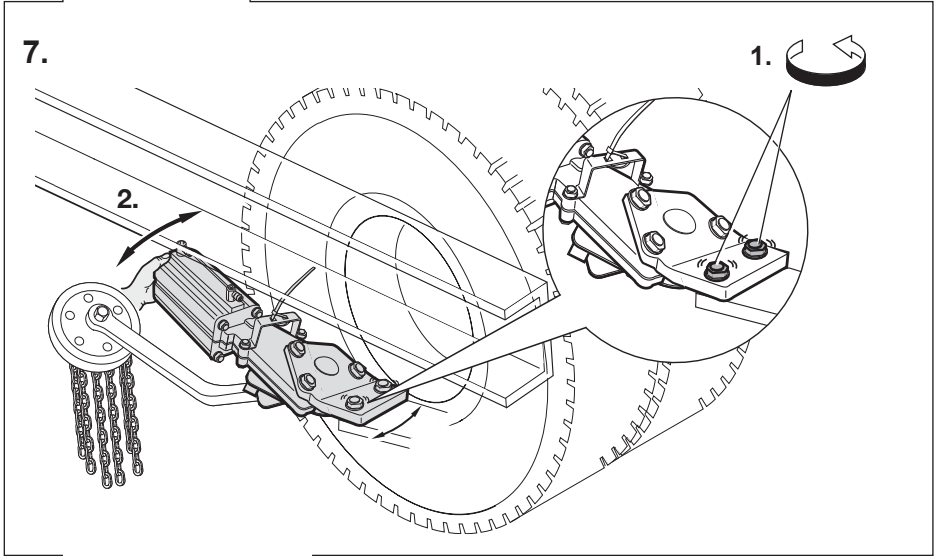
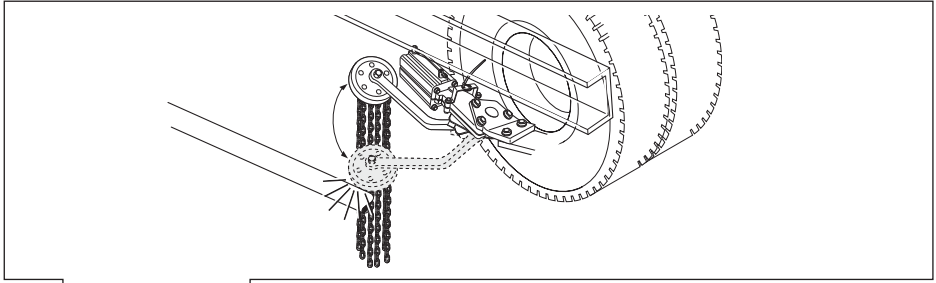

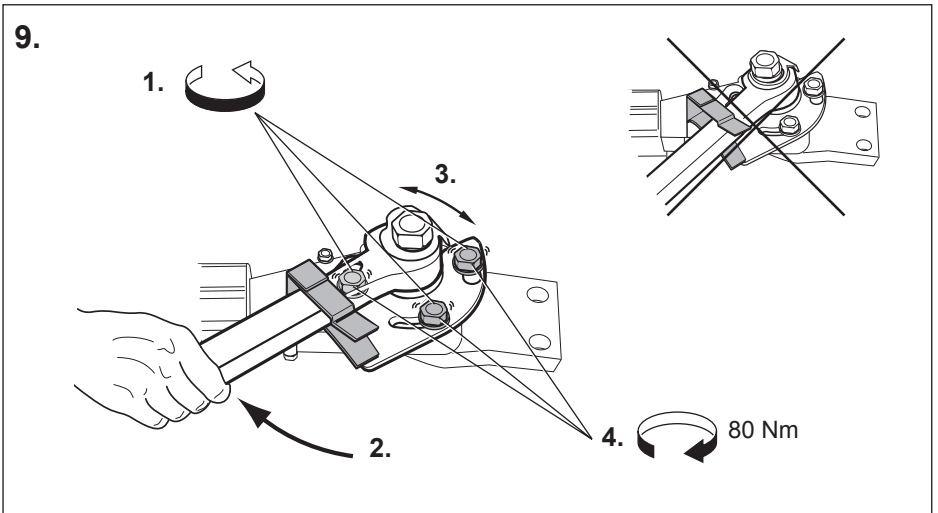
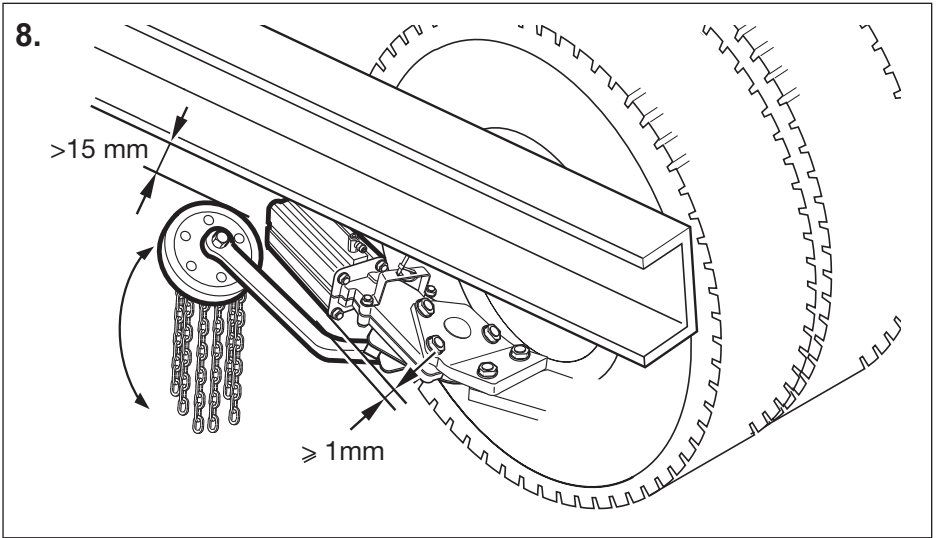
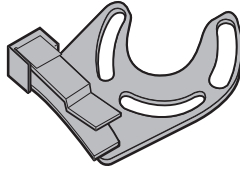

10.

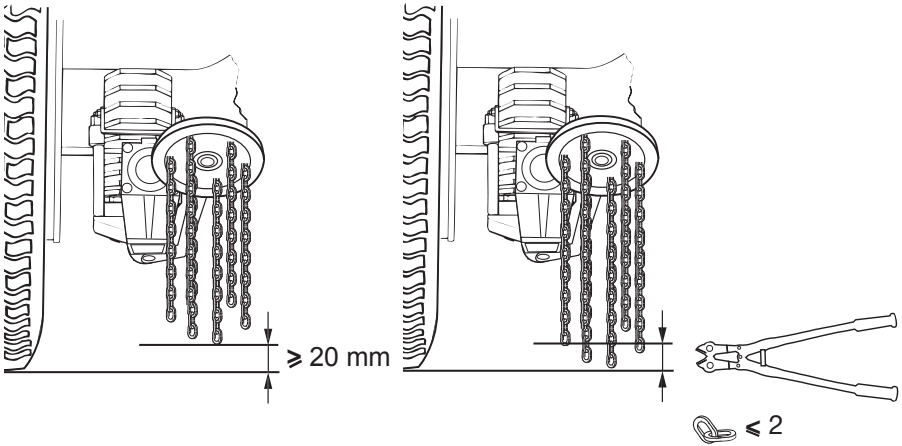

11.

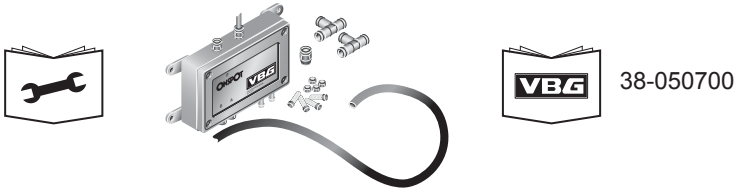



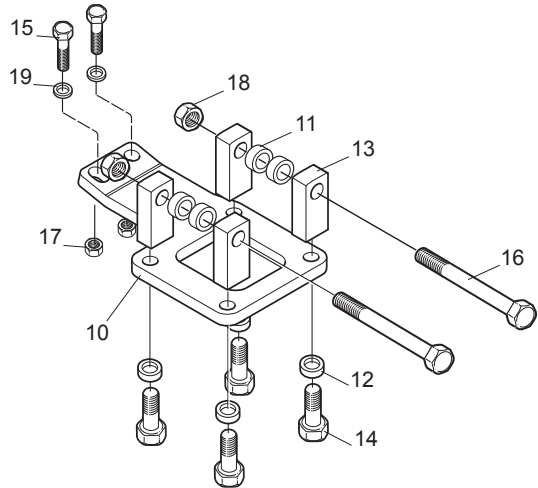
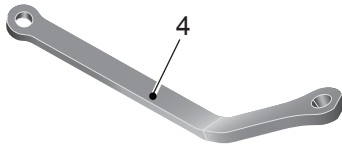
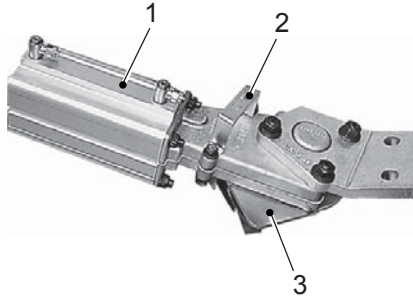
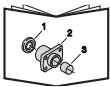

**DE 56-244100 56-320000**

Pos	Art.-nr	Bezeichnung	Anzahl	Pos	Art.-nr	Bezeichnung	Anzahl
<b>OnSpotaggregat und Arm</b>				<b>Befestigung</b>			
1	56-320501	OnSpot-Aggregat links (Stanznummer 56-319000)	1	10a	56-244201	Adapterplatte links	1
	56-320502	OnSpot-Aggregat rechts (Stanznummer 56-318900)	1	10b	56-244202	Adapterplatte rechts	1
2	56-320400	Schlauchhalter	2	11	56-045001	Distanzhülse L=10	8
3	56-320601	Stopper links, komplett (Stanznummer 56-318803)	1	12	56-200600	Distanzplatte T=6	12
	56-320602	Stopper rechts, komplett (Stanznummer 56-318804)	1	13	56-244300	Scheibe	8
4	56-324007	Arm links inkl. pos. 5 (Stanznummer 56-323001)	1	14	35-018000	Schraube M16x40	8
	56-324008	Arm rechts inkl. pos. 5 (Stanznummer 56-323002)	1	15	35-032700	Schraube M16x60	4
5	56-320700	Befestigungsteile für Arm	2	16	35-097400	Schraube M20x1,5x220	2
				17	36-013100	Mutter M16 nylock	4
				18	36-021200	Mutter M20x1,5 nylock	4
				19	37-000700	Scheibe BRB 17x30x3	16

Die VBG GROUP TRUCK EQUIPMENT AB behält sich das Recht auf Konstruktionsänderungen vor.

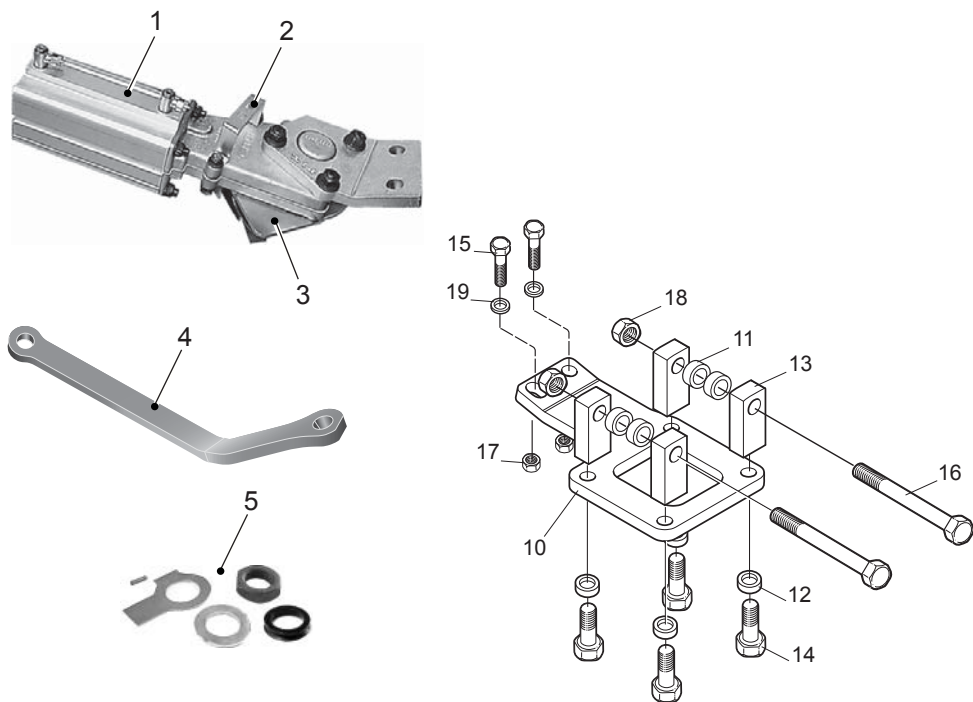

**DK 56-244100 56-320000**

Pos	Art..nr.	Betegnelse	Antal	Pos	Art.nr.	Betegnelse	Antal
		<b>OnSpotaggregat og arm</b>				<b>Konsol</b>	
1	56-320501	OnSpotaggregat venstre (ihugget nr. 56-319000)	1	10a	56-244201	Konsol, venstre	1
	56-320502	OnSpotaggregat højre (ihugget nr. 56-318900)	1	10b	56-244202	Konsol, højre	1
2	56-320400	Slangeholder	2	11	56-045001	Afstandsrør L=10	8
3	56-320601	Stop venstre, komplet (ihugget nr. 56-318803)	1	12	56-200600	Skive T=6	12
	56-320602	Stop højre, komplet (ihugget nr. 56-318804)	1	13	56-244300	Afstandsstykke	8
4	56-324007	Arm venstre inkl. pos. 5 (ihugget nr. 56-323001)	1	14	35-018000	Bolt M16x40	8
	56-324008	Arm højre inkl. pos. 5 (ihugget nr. 56-323002)	1	15	35-032700	Bolt M16x60	4
5	56-320700	Monteringsdele til arm	2	16	35-097400	Bolt M20x1,5x220	2
				17	36-013100	Møtrik M16 nylock	4
				18	36-021200	Møtrik M20x1,5 nylock	4
				19	37-000700	Skive BRB 17x30x3	16

VBG GROUP TRUCK EQUIPMENT AB forbeholder sig retten til konstruktionsændringer.

FI

**56-244100 56-320000**

Pos	Tuote no	Nimitys	Kpl	Pos	Tuote no	Nimitys	Kpl
		<b>OnSpot-laite ja varsi</b>				<b>Autokiinnike</b>	
1	56-320501	Vasen OnSpot-laite (meistetty nro 56-319000)	1	10a	56-244201	Vasen autokiinnike	1
	56-320502	Oikea OnSpot-laite (meistetty nro 56-318900)	1	10b	56-244202	Oikea autokiinnike	1
				11	56-045001	Väliputki L=10	8
2	56-320400	Letkupidin	2	12	56-200600	Aluslevy T=6	12
3	56-320601	Vasen rajoitinasennelma (meistetty nro 56-318803)	1	13	56-244300	Välilevy	8
	56-320602	Oikea rajoitinasennelma (meistetty nro 56-318804)	1	14	35-018000	Ruuvi M16x40	8
				15	35-032700	Ruuvi M16x60	4
4	56-324007	Vasen varsi sis. pos. 5 (meistetty nro 56-323001)	1	16	35-097400	Ruuvi M20x1,5x220	2
	56-324008	Oikea varsi sis. pos. 5 (meistetty nro 56-323002)	1	17	36-013100	Mutteri M16 nylock	4
				18	36-021200	Mutteri M20x1,5 nylock	4
5	56-320700	Varren asennusosat	2	19	37-000700	Aluslevy BRB 17x30x3	16

VBG GROUP TRUCK EQUIPMENT AB pidättää oikeuden muuttaa rakennetta.

FR

**56-244100 56-320000**

Pos	N°d'art.	Désignation	Qté	Pos	N°d'art.	Désignation	Qté
		<b>Groupe OnSpot et bras</b>				<b>Support de véhicule</b>	
1	56-320501	Groupe OnSpot gauche (No. 56-319000)	1	10a	56-244201	Support de véhicule, gauche	1
	56-320502	Groupe OnSpot droit (No. 56-318900)	1	10b	56-244202	Support de véhicule, droit	1
				11	56-045001	Entretoise L=10	8
2	56-320400	Support de tuyaux	2	12	56-200600	Tôle entretoise T=6	12
3	56-320601	Manivelle d'arrêt gauche complète (No. 56-318803)	1	13	56-244300	Rondelle	8
	56-320602	Manivelle d'arrêt droite complète (No. 56-318804)	1	14	35-018000	Vis M16x40	8
				15	35-032700	Vis M16x60	4
4	56-324007	Bras gauche, avec pos. 5 (No. 56-323001)	1	16	35-097400	Vis M20x1,5x220	2
	56-324008	Bras droit, avec pos. 5 (No. 56-323002)	1	17	36-013100	Ecrou M16 Nylock	4
				18	36-021200	Ecrou M20x1,5 Nylock	4
5	56-320700	Éléments de fixation du bras	2	19	37-000700	Rondelle 17x30	16

VBG GROUP TRUCK EQUIPMENT AB se réserve le droit de modifier ses constructions.

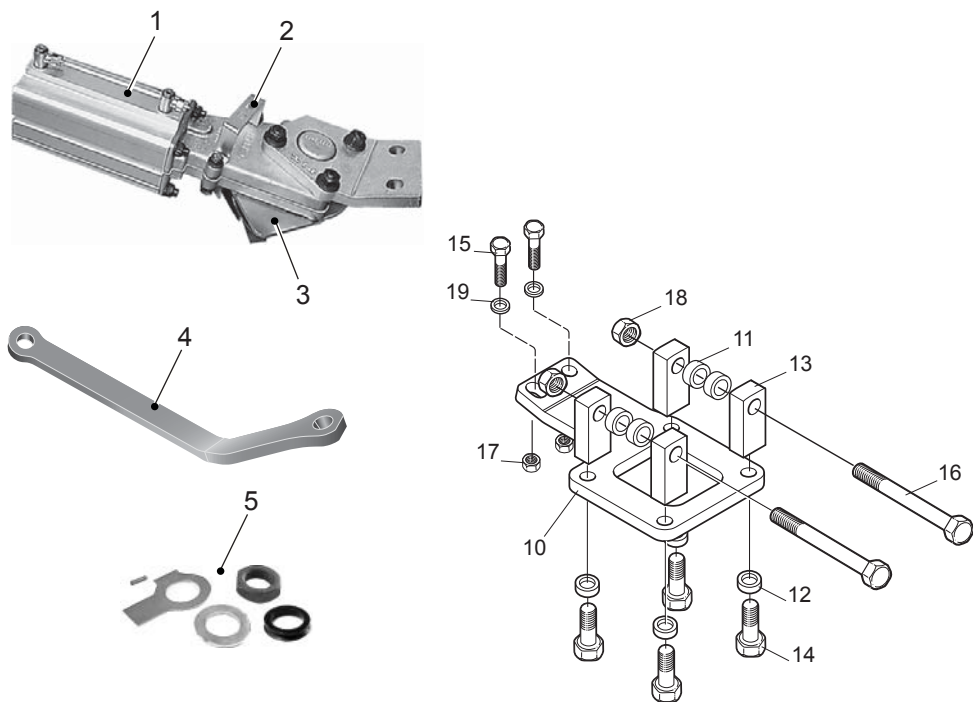

**GB 56-244100 56-320000**

Pos	Part no.	Description	Qty	Pos	Part no.	Description	Qty
<b>OnSpot-unit and arm</b>				<b>Vehicle bracket</b>			
1	56-320501	OnSpot unit left (stamped no. 56-319000)	1	10a	56-244201	Vehicle bracket, left	1
	56-320502	OnSpot unit right (stamped no. 56-318900)	1	10b	56-244202	Vehicle bracket, right	1
2	56-320400	Hose holder	2	11	56-045001	Spacing tube L=10	8
3	56-320601	Stop knob left, complete (stamped no. 56-318803)	1	12	56-200600	Spacing plate T=6	12
	56-320602	Stop knob right, complete (stamped no. 56-318804)	1	13	56-244300	Spacer	8
4	56-324007	Arm left, incl. pos. 5 (stamped no. 56-323001)	1	14	35-018000	Screw M16x40	8
	56-324008	Arm right, incl. pos. 5 (stamped no. 56-323002)	1	15	35-032700	Screw M16x60	4
5	56-320700	Arm fasteners	2	16	35-097400	Screw M20x1,5x220	2
				17	36-013100	Nut M16 Nylock	4
				18	36-021200	Nut M20x1,5 Nylock	4
				19	37-000700	Washer 17x30	16

VBG GROUP TRUCK EQUIPMENT AB reserve the right to amend or alter specifications at their discretion.

IT

**56-244100 56-320000**

Pos.	Codice	Descrizione	Q	Pos.	Codice	Descrizione	Q
		<b>Unità OnSpot e braccio</b>				<b>Staffe per montaggio al veicolo</b>	
1	56-320501	Unità OnSpot sinistra (n°identificativo 56-319000)	1	10a	56-244201	Staffa sinistra	1
	56-320502	Unità OnSpot destra (n°identificativo 56-318900)	1	10b	56-244202	Staffa destra	1
2	56-320400	Supporto del flessibile	2	11	56-045001	Distanziale L=10	8
3	56-320601	Manovella d'arresto sinistra, completa (n°identificativo 56-318803)	1	12	56-200600	Rondella T=6	12
	56-320602	Manovella d'arresto destra, completa (n°identificativo 56-318804)	1	13	56-244300	Distanziale	8
4	56-324007	Braccio sinistro, incl. pos. 5 (n°identificativo 56-323001)	1	14	35-018000	Vite M16x40	8
	56-324008	Braccio destro, incl. pos. 5 (n°identificativo 56-323002)	1	15	35-032700	Vite M16x60	4
5	56-320700	Elementi di fissaggio del braccio	2	16	35-097400	Vite M20x1,5x220	2
				17	36-013100	Dado M16 nylock	4
				18	36-021200	Dado M20x1,5 nylock	4
				19	37-000700	Rondella BRB 17x30x3	16

VBG GROUP TRUCK EQUIPMENT AB si riserva il diritto di modifica senza preavviso.

LV

**56-244100 56-320000**

Poz.	Det.nr.	Nosaukums	Skaits	Poz.	Det.nr.	Nosaukums	Skaits
		<b>OnSpot agregāts un svira</b>				<b>Automašīnas kronšteins</b>	
1	56-320501	OnSpot agregāts, kreisais (marķējuma № 56-319000)	1	10a	56-244201	Automašīnas kronšteins, kreisais	1
	56-320502	OnSpot agregāts, labais (marķējuma № 56-318900)	1	10b	56-244202	Automašīnas kronšteins, labais	1
2	56-320400	Šļūtenes turētājs	2	11	56-045001	Spraišļa caurule L=10	8
3	56-320601	Izslēgšanas poga, kreisā, komplekts, (marķējuma № 56-318803)	1	12	56-200600	Paplāksne T=6	12
	56-320602	Izslēgšanas poga, labā, komplekts, (marķējuma № 56-318804)	1	13	56-244300	Starplāksne	8
4	56-324007	Svira, kreisā, iesk. poz. 5 (marķējuma № 56-323001)	1	14	35-018000	Skrūve M16x40	8
	56-324008	Svira, labā, iesk. poz. 5 (marķējuma № 56-323002)	1	15	35-032700	Skrūve M16x60	4
5	56-320700	Sviru stiprinājumi	2	16	35-097400	Skrūve M20x1,5x220	2
				17	36-013100	Uzgrieznis M16 nylock	4
				18	36-021200	Uzgrieznis M20x1,5 nylock	4
				19	37-000700	Paplāksne BRB 17x30x3	16

VBG GROUP TRUCK EQUIPMENT AB saglabā tiesības izdarīt izmaiņas izstrādājumu konstrukcijās.

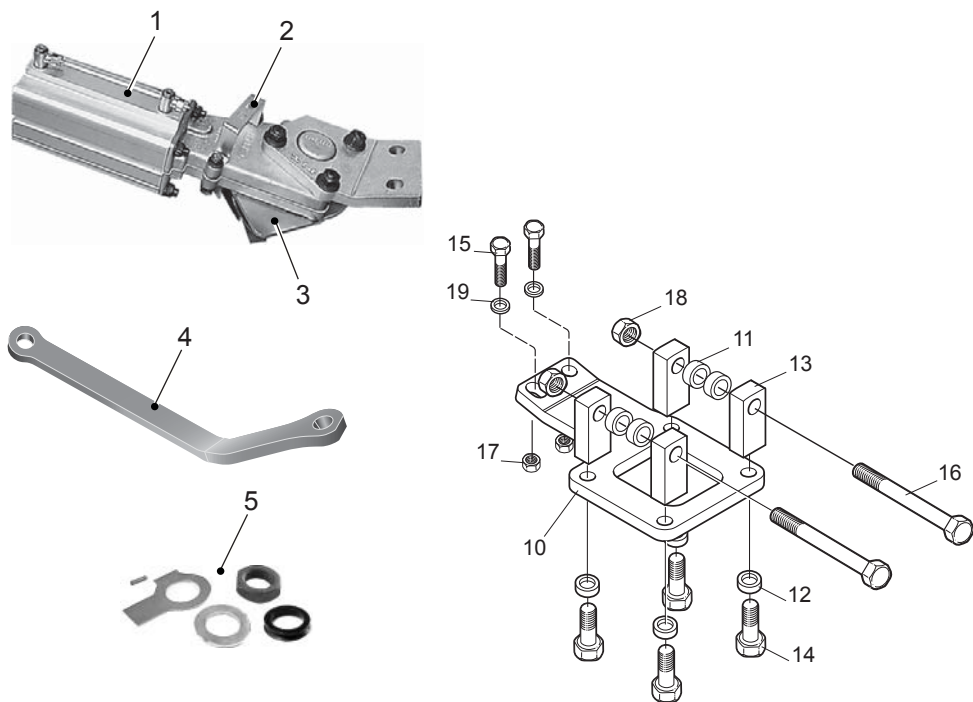

**NO 56-244100 56-320000**

Pos	Art.nr	Navn	Antall	Pos	Art.nr	Navn	Antall
<b>OnSpotaggregat og arm</b>				<b>Bilfeste</b>			
1	56-320501	OnSpot-aggregat venstre (identifikationsnr 56-319000)	1	10a	56-244201	Bilfeste venstre	1
	56-320502	OnSpot-aggregat høyre (identifikationsnr 56-318900)	1	10b	56-244202	Bilfeste høyre	1
2	56-320400	Slangeholder	2	11	56-045001	Avstandsrør L=10	8
3	56-320601	Stopperatt venstre, komplett (identifikationsnr 56-318803)	1	12	56-200600	Skive T=6	12
	56-320602	Stopperatt høyre, komplett (identifikationsnr 56-318804)	1	13	56-244300	Avstandsskive	8
4	56-324007	Arm venstre inkl. pos. 5 (identifikationsnr 56-323001)	1	14	35-018000	Skrue M16x40	8
	56-324008	Arm høyre inkl. pos. 5 (identifikationsnr 56-323002)	1	15	35-032700	Skrue M16x60	4
5	56-320700	Festedetaljer for arm	2	16	35-097400	Skrue M20x1,5x220	2
				17	36-013100	Mutter M16 nylock	4
				18	36-021200	Mutter M20x1,5 nylock	4
				19	37-000700	Skive BRB 17x30x3	16

VBG GROUP TRUCK EQUIPMENT AB forbeholder seg retten til konstruksjonsendringer.

PL

**56-244100 56-320000**

Poz.	Nr części	Nazwa	Ilość	Poz.	Nr części	Nazwa	Ilość
		<b>Urządzenie OnSpot i ramię</b>				<b>Zamocowanie do pojazdu</b>	
1	56-320501	Urządzenie OnSpot strona lewa (wybity numer 56-319000)	1	10a	56-244201	Zamocowanie do pojazdu, lewe	1
	56-320502	Urządzenie OnSpot strona prawa (wybity numer 56-318900)	1	10b	56-244202	Zamocowanie do pojazdu, prawe	1
2	56-320400	Uchwyt przewodu giętkiego	2	11	56-045001	Tuleja odległościowa L=10	8
3	56-320601	Pokrętko oporowe lewe, komplet (wybity numer 56-318803)	1	12	56-200600	Podkładka T=6	12
	56-320602	Pokrętko oporowe prawo, komplet (wybity numer 56-318804)	1	13	56-244300	Element odległościowy	8
4	56-324007	Ramię lewe, włącznie z poz. 5 (wybity numer 56-323001)	1	14	35-018000	Śruba M16x40	8
	56-324008	Ramię prawe, włącznie z poz. 5 (wybity numer 56-323002)	1	15	35-032700	Śruba M16x60	4
5	56-320700	Arm fasteners	2	16	35-097400	Śruba M20x1,5x220	2
				17	36-013100	Nakrętka M16 Nylock	4
				18	36-021200	Nakrętka M20x1,5 Nylock	4
				19	37-000700	Podkładka BRB 17x30x3	16

VBG GROUP TRUCK EQUIPMENT AB zastrzega sobie prawo wprowadzania zmian produktów bez uprzedzenia.

SE

**56-244100 56-320000**

Pos	Det.nr	Benämning	Antal	Pos	Det.nr	Benämning	Antal
		<b>OnSpotaggregat och arm</b>				<b>Bilfäste</b>	
1	56-320501	OnSpotaggregat vänster (instansat nr 56-319000)	1	10a	56-244201	Bilfäste, vänster	1
	56-320502	OnSpotaggregat höger (instansat nr 56-318900)	1	10b	56-244202	Bilfäste, höger	1
2	56-320400	Slanghållare	2	11	56-045001	Distansrör L=10	8
3	56-320601	Stoppvred vänster, komplett (instansat nr 56-318803)	1	12	56-200600	Bricka T=6	12
	56-320602	Stoppvred höger, komplett (instansat nr 56-318804)	1	13	56-244300	Distans	8
4	56-324007	Arm vänster inkl. pos. 5 (instansat nr 56-323001)	1	14	35-018000	Skruv M16x40	8
	56-324008	Arm höger inkl. pos. 5 (instansat nr 56-323002)	1	15	35-032700	Skruv M16x60	4
5	56-320700	Fästdetaljer för arm	2	16	35-097400	Skruv M20x1,5x220	2
				17	36-013100	Mutter M16 nylock	4
				18	36-021200	Mutter M20x1,5 nylock	4
				19	37-000700	Bricka BRB 17x30x3	16

VBG GROUP TRUCK EQUIPMENT AB förbehåller sig rätten till konstruktionsförändringar.

**AUSTRALIA**

TRANSPEC LIMITED  
P O Box 217 1 Cherry Lane  
AU - 3028 P.O LAVERTON, VIC 3028  
Tel +61 3 92 67 24 44  
Fax +61 3 93 69 48 26

**BELGIUM**

VBG GROUP SALES BENELUX NV  
Lochtemanweg 50  
B-3580 BERINGEN  
Tel +32 11 458 379  
Fax +32 11 458 378

**DENMARK**

VBG GROUP SALES A/S  
Industribuen 20-22  
DK - 5592 EJBY  
Tel +45 6446 1919  
Fax +45 6446 1088

**ESTONIA**

GOKART AS  
Peterburi tee 111  
EE-11415 TALLINN  
Tel +372 623 0622  
Faks +372 623 0621

**FINLAND**

H KRAATZ OY  
Ruukkimestariintie 9  
FI - 02330 ESPOO  
Tel +358 9 8093100  
Fax +358 9 80931099

**FRANCE**

ONSPOT Sàrl  
14 Route de Sarrebruck  
FR - 57645 MONTROY-FLANVILLE  
Tel +33 3 8776 3080  
Fax +33 3 8776 1944

**GERMANY**

VBG GROUP TRUCK EQUIPMENT GMBH  
Oberschlesienstrasse 15  
DE - 47807 KREFELD  
Tel +49 2151 835 0  
Fax +49 2151 835 200

**GREAT BRITAIN**

VBG GROUP SALES LIMITED  
Unit 9 Willow Court  
West Quay Road  
Winwick Quay  
Warrington  
Cheshire WA2 8UF  
Tel +44 1925 234111  
Fax +44 1925 234222

**ICELAND**

OSAL OSKAR ANDERSSON  
Tangarhofdi 4  
IS - 110 REYKJAVIK  
Tel +354 587 6619  
Fax +354 187 7719

**IRELAND**

NEWBRIDGE METAL PRODUCTS  
Toughers Business Park  
IE - NEWHALL, Naas, Co Kildare, Eire  
Tel +353 45 431 502  
Fax +353 45 433 747

**ISRAEL**

H KLEIN & SONS LTD  
P O Box 1093  
Industrial Area-North  
IL - ASHDOD 77109  
Tel +972 8856 4330  
Fax +972 8856 4324

**ITALY**

MAGGI CANTENE S.P.A  
Via Milano 2/4  
I- 23854 Olginate  
ITALY  
Tel +39 0341 60 52 35  
Fax +39 0341 60 53 52

**JAPAN**

SHINKO BOEKI CO LTD  
Shibuya Central Bldg  
3-14 Udagawa-cho, Shibuya-ku,  
JP - TOKYO 150  
Tel +81 3 33463 0941  
Fax +81 3 33463 1707

**NETHERLANDS**

VBG GROUP SALES BENELUX NV  
Alaertslaan 12  
NL-5801 DC Venray  
Tel +31 478 514 143  
Fax +31 478 515 790

**NEW ZEALAND**

TRANSPORT SPECIALTIES LTD  
P O BOX 98-971  
NZ - S.A.M.C., Wiri, AUCKLAND  
Tel +64 9 980 7300  
Fax +64 9 980 7306

**NORWAY**

VBG GROUP SALES AS  
Postboks 94 Leirdal  
NO - 1009 OSLO  
Tel +47 23 14 16 60  
Fax +47 23 14 16 61

**POLAND**

HYVA POLSKA Sp. z o.o.  
ul. Mysłowska 68  
PL - 30718 KRAKÓW  
Tel +48 12 658 65 05  
Fax +48 12 658 44 39

**SOUTH AFRICA**

TRANSPORT TECHNOLOGY  
Greenside 2034  
ZA - 1450 JOHANNESBURG  
Tel +27 11 7810491  
Fax +27 11 7894441

**SWEDEN**

VBG GROUP TRUCK EQUIPMENT AB  
Box 1216  
SE - 462 28 VÄNERSBORG  
Tel +46 521 277700  
Fax +46 521 277795

**Branch office:**

VBG GROUP TRUCK EQUIPMENT AB  
Umestans Företagspark Hus 2  
SE - 903 47 UMEA  
Tel +46 90 271 10  
Fax +46 90 326 11

**SWITZERLAND**

AGL für LASTWAGENZUBEHÖRE  
Postfach  
CH - 6048 HORW  
Tel +41 41 340 25 25  
Fax +41 41 340 31 79

**SWITZERLAND**

AMBOFIX METALLBAU  
U. Ambühl  
Am Schachenrain 36  
CH - 4562 BIBERIST  
Tel +41 32 6 72 36 83  
Fax +41 32 67 22 267

**TANZANIA**

SUPERDOLL TRAILERS MANUFACTURE CO. LTD  
P.O Box 16541  
TZ - DAR ES SALAAM  
Tel +255 22 2860930  
Fax +255 22 2865412

---

**VBG GROUP TRUCK EQUIPMENT AB**

Herman Kreftings gata 4

Box 1216

SE-462 28 VÄNERSBORG

Tel +46 521 27 77 00

E-mail [info@vbg.se](mailto:info@vbg.se)

[www.vbg.se](http://www.vbg.se)