



AUTOMATIC TIRE CHAINS

VEHICLE SUSPENSION INFORMATION

Neway ADZ

Form #3130070

The following information and measurements are required in order to determine if the vehicle can be fit with Onspots, and, if so, which Model Onspot Chain Set and Mounting Bracket Kit is required. This information will be different from vehicle to vehicle based on vehicle make/ model, axle make/model, tire size, and wheel offset. Any questions in completing this form can be addressed to Onspot at 800-224-2467. OEM NOTE: Please indicate if chassis has no body.

Dealer or OEM name: _____

Customer name: _____ Ref. Unit No. _____

Address: _____

City: _____ State: _____ Zip: _____

Contact: _____ Phone Number: _____

Quantity of identical vehicles for this order: _____

Description: (Fire Truck, Dump Truck, etc.) _____

Vehicle Make: _____ Model: _____ Year: _____

Note: The following information applies to the rear suspension only.

Axle Make: _____ Capacity: _____ Tandem/Single

Tire Size: _____ Brand: _____

Air Brakes: Yes/No

Disc Brakes: Yes/No

Are there any obstructions within 36" in front of drive rear axle that would prevent the Onspot Installation? (i.e. air tank, exhaust, driveline retarder, cabinets, etc.)

If so indicate item and distance from AXLE, from GROUND, and from TIRE SIDEWALL.

VEHICLE SUSPENSION INFORMATION

Name _____ Unit # _____

(please circle) Axle Measuring FRONT / REAR

	DRIVER	PASSENGER
"GB"	_____	_____
"C"	_____	_____
"SB"	_____	_____
"BG"	_____	_____

"GB" Distance from the lowest point on the brake chamber to the ground.

"C" Distance from the side of the beam to the tire sidewall right beside the beam.

"SB" Distance from the tire sidewall to the center of the brake chamber.

"BG" Distance from the bottom of the beam to the ground at location illustrated.

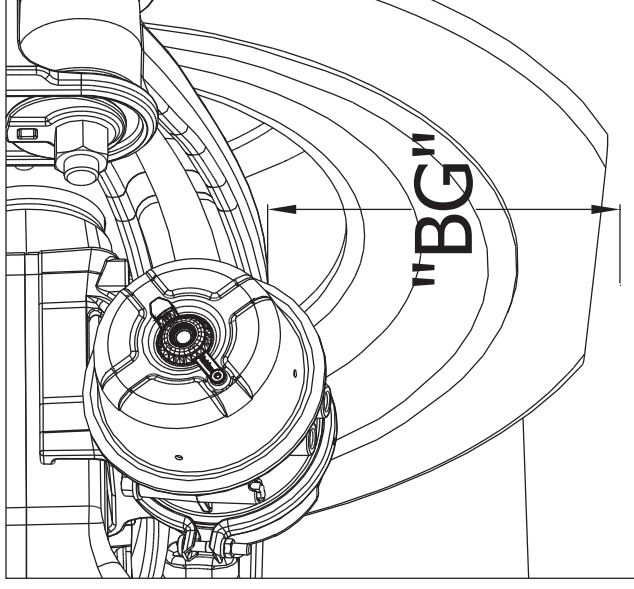
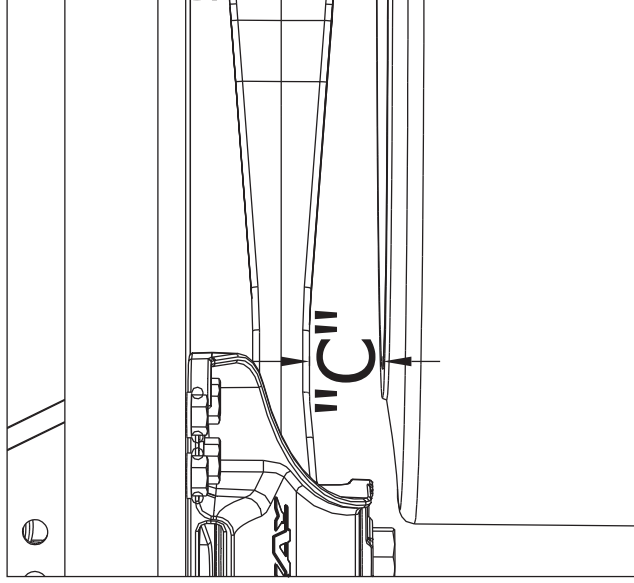
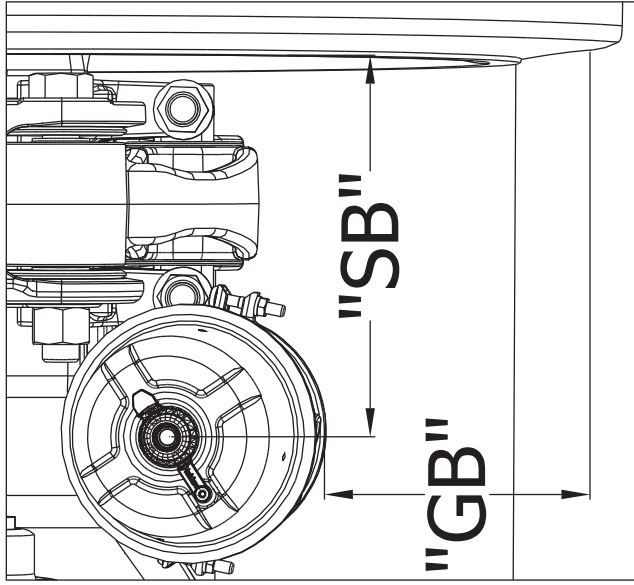

QUESTIONS? 1-800-224-2467
FAX COMPLETED FORM TO: 812-346-1819
OR EMAIL TO: service@onspot.com