

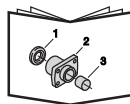



Ford Transit Singel Tyre

56-244900

56-322001

- DE** Blattfederung
- DK** Bladfjedre
- FI** Lehtijousitus
- FR** Suspension à lames
- GB** Plate suspension
- IT** Sospensioni a balestra
- LV** Plāksnes pakarināšana
- NO** Bladfjæring
- PL** Zawieszenie plytki
- SE** Bladfjädring

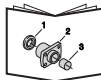

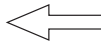
	Montageanleitung Monteringvejledning Asennusohje	Instructions de montage Mounting instruction Istruzioni di montaggio	Montāžas instrukcija Monteringsanvisning Instrukcja montażowa Monteringsanvisning
	Ersatzteilliste Reservedeliste Varaosaluettelo	Liste des pièces détachées Spare Parts List Parti di ricambio	Rezerves daļu saraksts Reservedeliste Lista czæúci zamiennych Reservdelista
	Anleitungen des Herstellers Producentens anvisning Valmistajan ohjeet	Instructions du fabricant Manufacturer's instruction Istruzioni del produttore	Ražotāja norādījumi Produsentens anvisning Wskazówki producenta Tillverkarens anvisning
	Anweisungen des LKW-Herstellers Lastbilfabrikantens anvisning Ajoneuvon valmistajan ohjeet Instruction du constructeur Vehicle manufacture instruction	Istruzioni del produttore del carrello Autorūpnīcas instrukcija Lastebilproducentens anvisning Instrukcja producenta pojazdu Lastvagnstillverkarens anvisning	
	Fahrtrichtung Kørselsretning Ajosuunta	Sens de conduite Direction of travel Senso di marcia	Kustības virziens Kjøreretning Kierunek jazdy Färdriktning

Allgemein

Die Montage darf nur von ausgebildetem und kompetentem Fachpersonal durchgeführt werden und muß in einer befugten Werkstatt erfolgen, die über erforderliche Werkzeuge und Ausrüstungen verfügt, und in der Zugänglichkeit und Sicherheit gegeben sind. Alle Teile vor der Montage identifizieren. Anweisungen befolgen.

Empfohlene Einstellungen nicht ändern. Übergeben Sie dem Kunden alle Anweisungen und Instruktionen zur Aufbewahrung im Fahrzeug für künftige Service- und Wartungsarbeiten.

 Befolgen Sie die Anweisungen des LKW-Herstellers

Generelt

Monteringen skal foretages af uddannet og kompetent personale og ske på autoriseret værksted, der råder over det nødvendige værktøj og udstyr, og hvor der sikres tilgængelighed og sikkerhed. Kontroller at alle dele er til stede inden montering. Følg anvisningerne.

Anbefalede indstillinger må ikke ændres. Giv kunden alle anvisninger og instruktioner, så de kan lægges i bilen til brug ved fremtidig service og vedligeholdelse.

 Følg lastbilfabrikantens anvisninger



Yleistä

Laitteisto on asennettava valtuutetussa korjaamossa, jonka koulutetulla ja ammattitaitoisella henkilökunnalla on käytössään tarvittavat työkalut ja varusteet ja jossa on turvalliset työskentelyolot. Tunnista kaikki osat ennen asennusta. Noudata ohjeita.

Älä muuta suositeltuja säätöjä. Luovuta kaikki ohjeet asiakkaalle säilytettäväksi autossa tulevia huoltoja ja kunnossapitoa varten.



Noudata ajoneuvon valmistajan ohjeita



Généralités

Le montage doit être effectué par des personnes possédant la compétence et la formation requises, dans un atelier autorisé disposant des outils et équipements nécessaires et où l'accessibilité et la sécurité peuvent être assurées. Identifier tous les composants avant de procéder au montage. Suivre les instructions.

Ne pas modifier les réglages recommandés. Toutes les informations et toutes les instructions doivent être remises au client afin d'être conservées dans le véhicule et utilisées pour les opérations d'entretien futures.



Se conformer également aux instructions du constructeur du camion



General

Installation work should be carried out by trained and skilled staff. It should be performed at an authorised workshop where the required tools and equipment are available and where provisions can be made for accessibility and safety. Identify all components prior to installation. Follow the instructions.

Do not alter the recommended settings. Give the customer all directives and instructions so that these can be kept in the vehicle for future service and maintenance.



Follow the instructions of the vehicle manufacturer



Generalità

Il montaggio deve essere effettuato da personale competente e dotato della formazione richiesta, in una officina autorizzata, in possesso delle necessarie attrezzature e dove accessibilità e sicurezza possano essere garantite. Identificare tutti i componenti prima di procedere al montaggio. Seguire le istruzioni.

Non modificarne le raccomandazioni. Tutte le informazioni e tutte le istruzioni devono essere trasmesse al cliente e conservate a corredo del veicolo per essere utilizzate nelle operazioni di successiva manutenzione.



Attenersi altresì alle istruzioni del costruttore del veicolo.



Vispārēji norādījumi

Uzstādīšanas darbi jāveic trenētām un apmācītam personālam. Tie jāizpilda autorizētā darbnīcā, kur ir pieejami nepieciešamie darbarīki un aprīkojums un kur ir nepieciešamie nosacījumi, lai nodrošinātu piekļuvi un drošību. Pirms montāžas identificējiet visas detaļas. Sekojiet norādījumiem. Neizmainiet ieteiktos iestatījumus. Visus norādījumus un instrukcijas izsniedziet klientam, lai tās tiktu uzglabātas automobilī un būtu pieejamas servisa un apkopes gadījumos.



Ievērojiet automašīnas izgatavotāja instrukcijas.



Generelt

Monteringen skal utføres av kompetent personell med nød-vendig opplæring, og skal skje på autorisert verksted hvor nødvendig verktøy og utstyr er tilgjengelig og sikkerheten kan ivaretas. Identifiser alle deler før montering. Følg anvisningene.

Ikke foreta endringer av anbefalte innstillinger. Overlever alle anvisninger og instruksjoner til kunden for oppbevaring i kjøretøyet for fremtidig service og vedlikehold.



Følg lastebilprodusentens anvisninger



Informacje ogólne

Montaż powinien być wykonywany wyłącznie przez przeszkolonych i kompetentnych pracowników. Powinien być wykonany w autoryzowanym punkcie obsługi technicznej, gdzie znajdują się wymagane narzędzia i wyposażenie oraz gdzie może być zapewniony odpowiedni dostęp i bezpieczeństwo. Zapoznaj się z poszczególnymi częściami przed przystąpieniem do montażu. Stosuj się do instrukcji. Nie zmieniaj zalecanych ustawień. Wszystkie wskazówki i instrukcje należy przekazać klientowi w celu przechowywania ich w pojeździe i wykorzystywania przy okazji przyszłych czynności serwisowych i konserwacyjnych.



Postępuj zgodnie z instrukcją producenta pojazdu.



Allmänt

Monteringen skall utföras av utbildad och kompetent personal och ske på auktoriserad verkstad där erforderliga verktyg och utrustning finns och där åtkomlighet och säkerhet kan tillgodoses. Identifiera alla delar före montering. Följ anvisningarna.

Ändra ej rekommenderade inställningar. Lämna alla anvisningar och instruktioner till kunden att förvaras i fordonet för framtida service och underhåll.



Följ lastvagnstillverkarens anvisningar

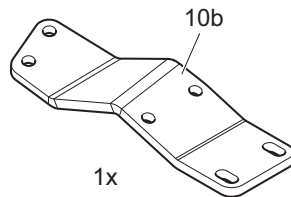
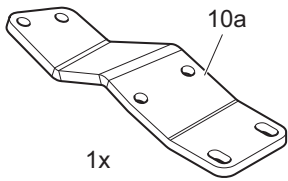
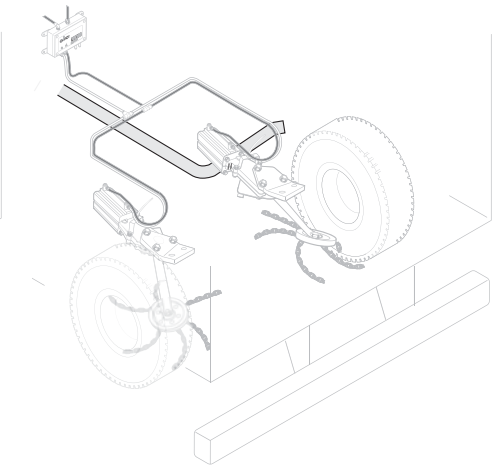
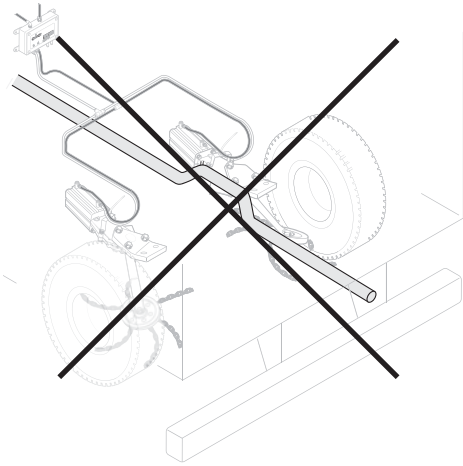

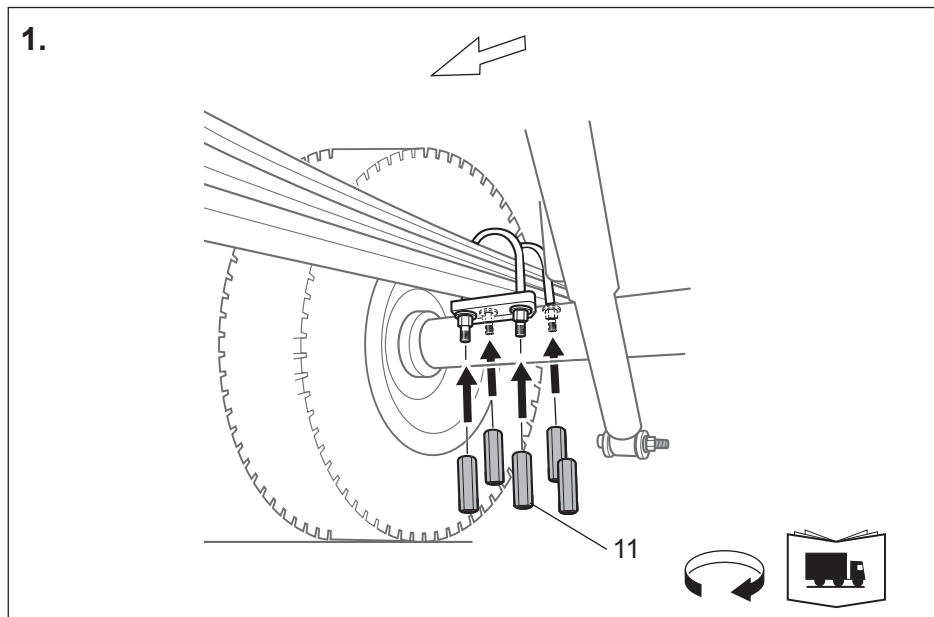
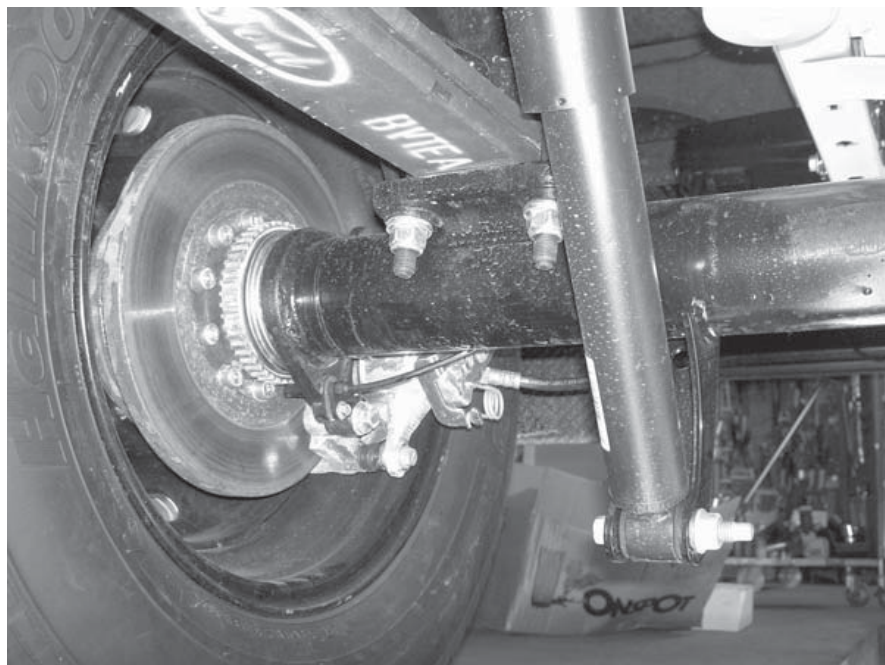

2.

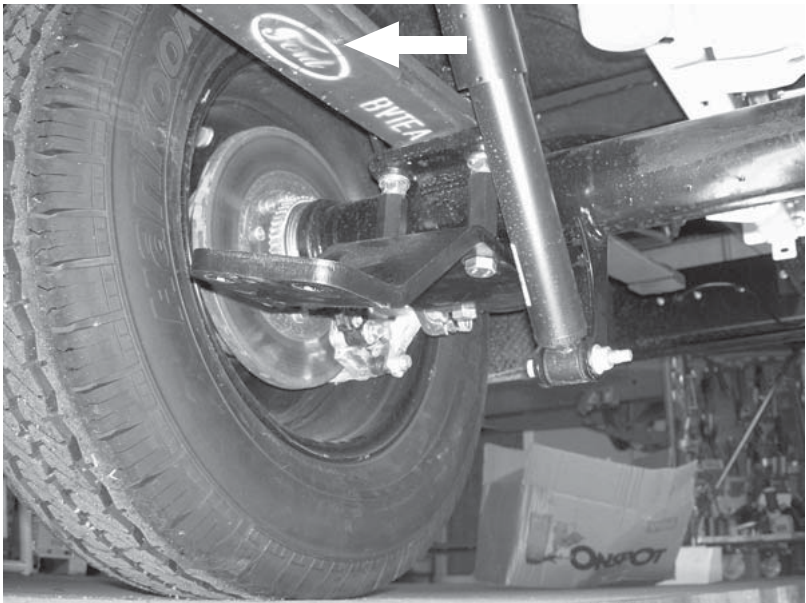
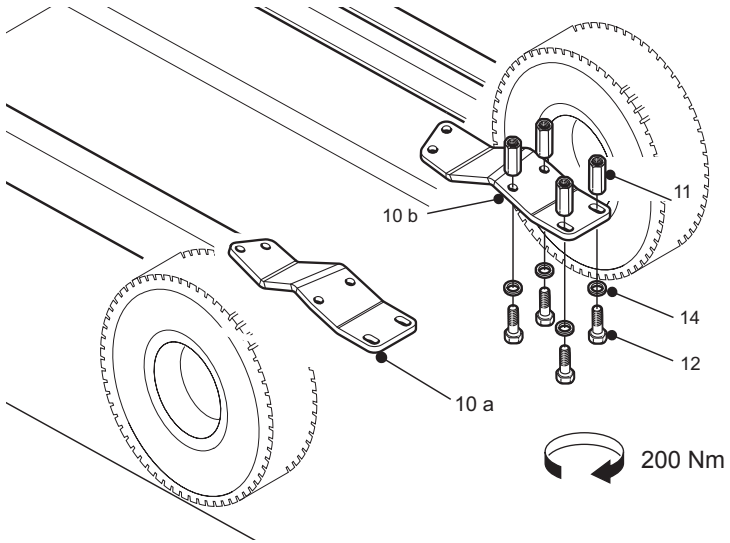

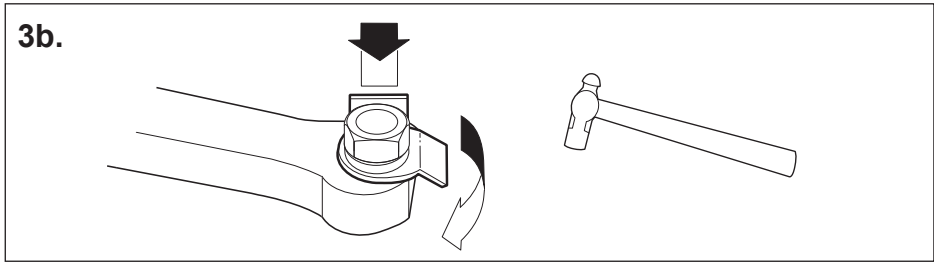
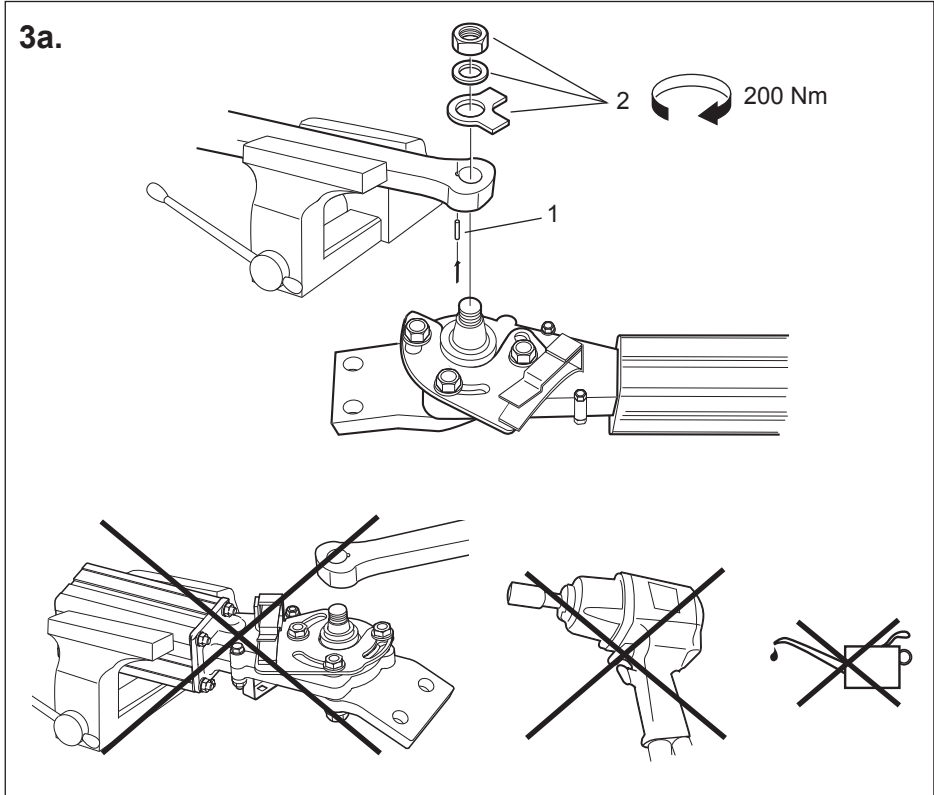
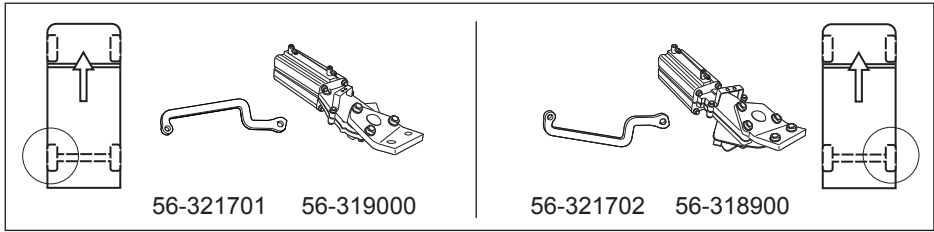

4.

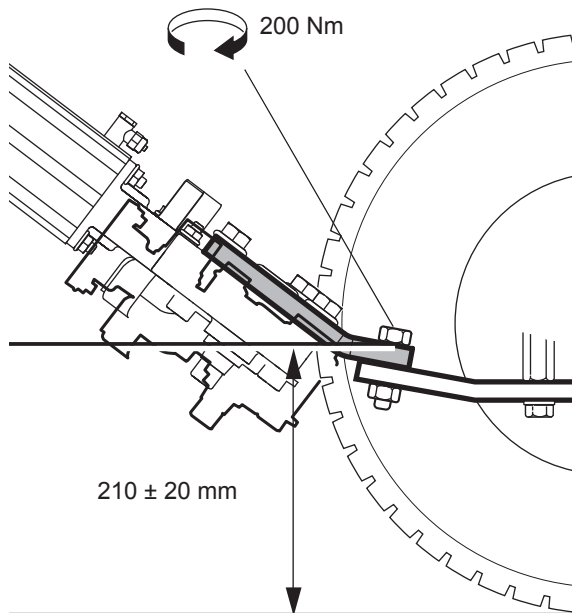
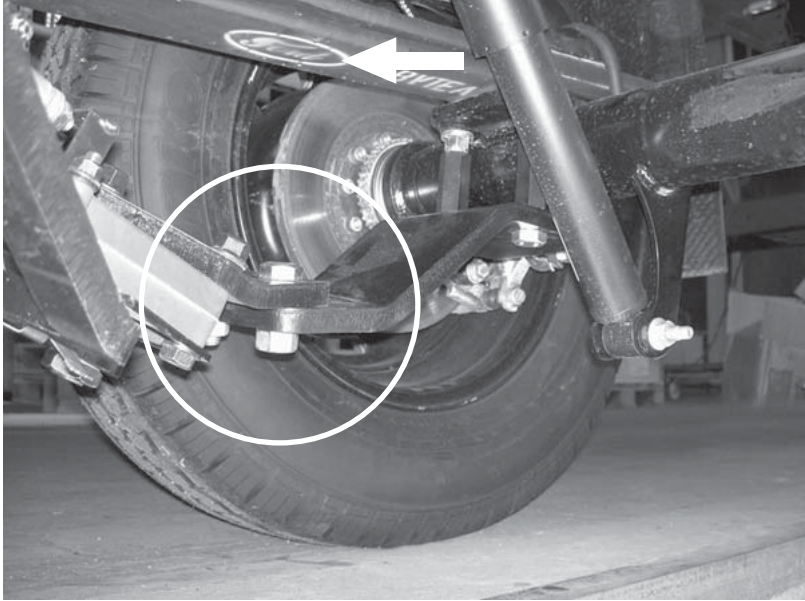

5.

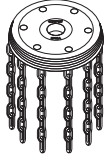

38-155900

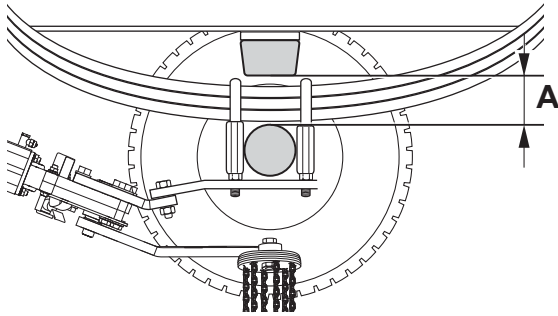
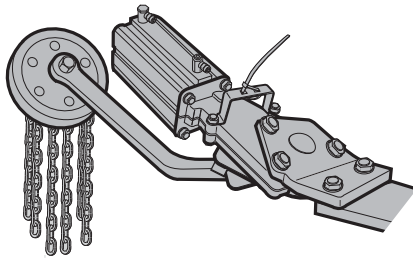

6.

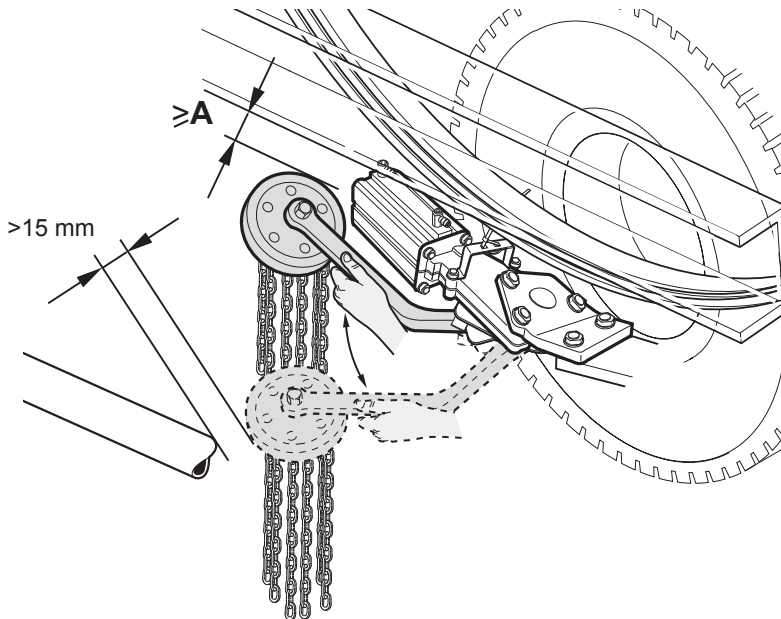

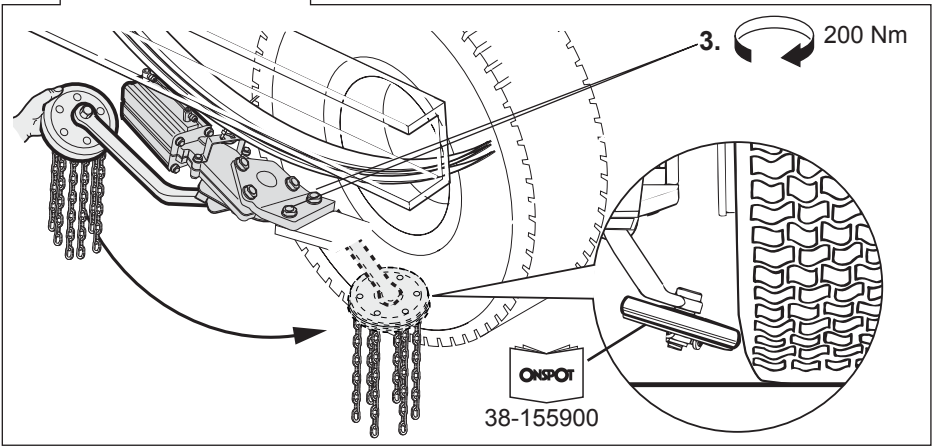
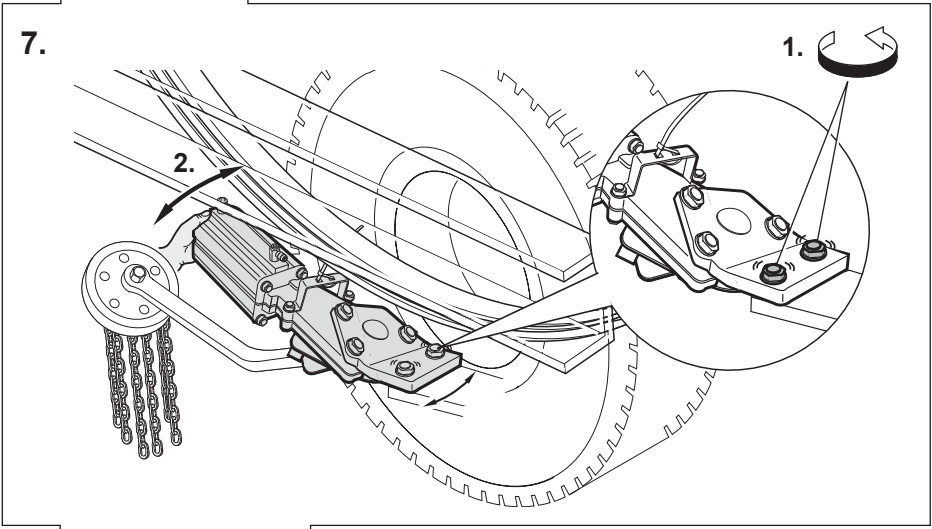
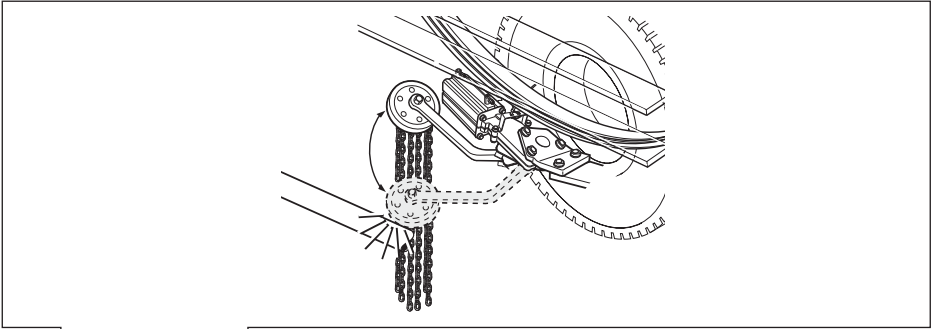

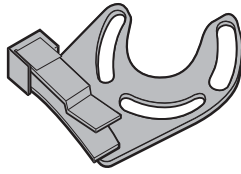

8.

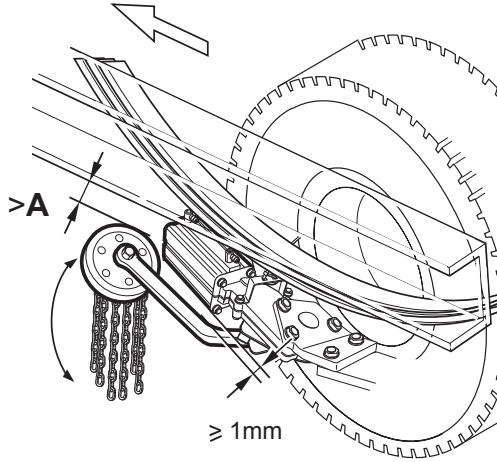

9.

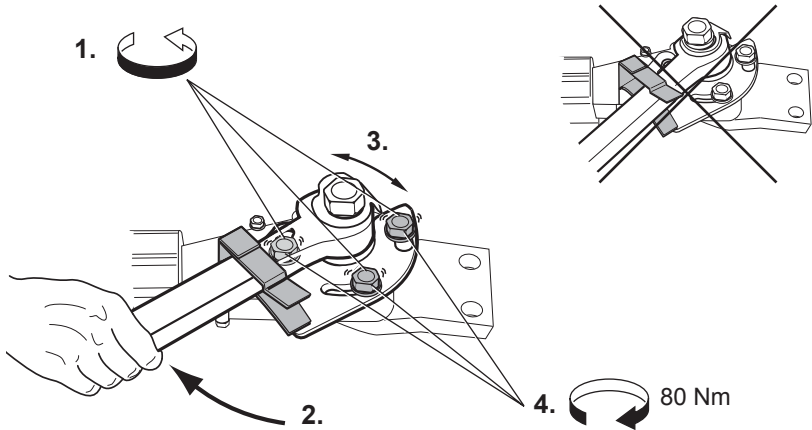

10.

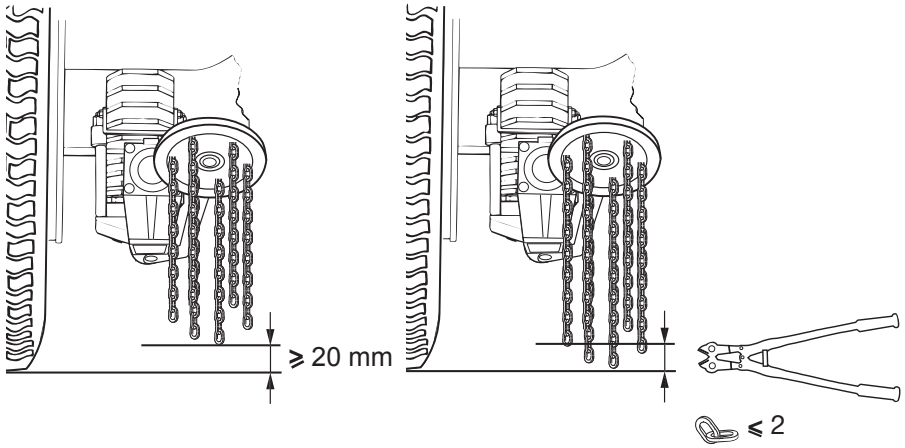

11.

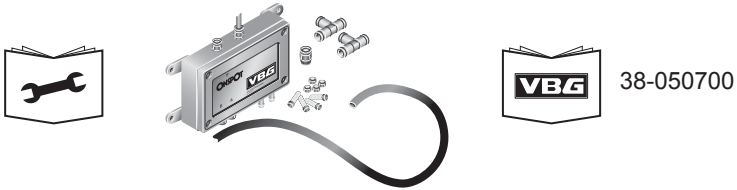

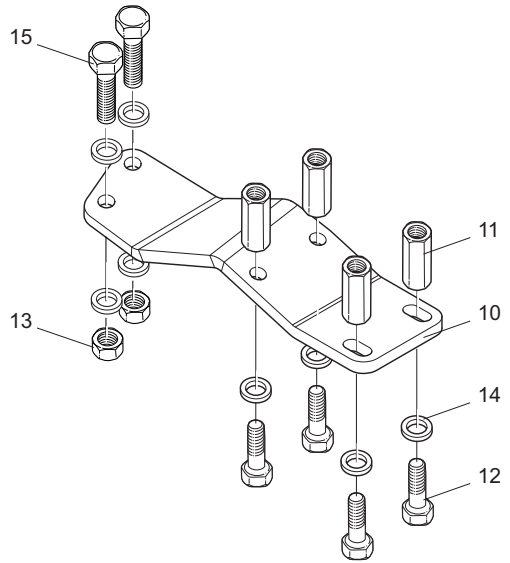
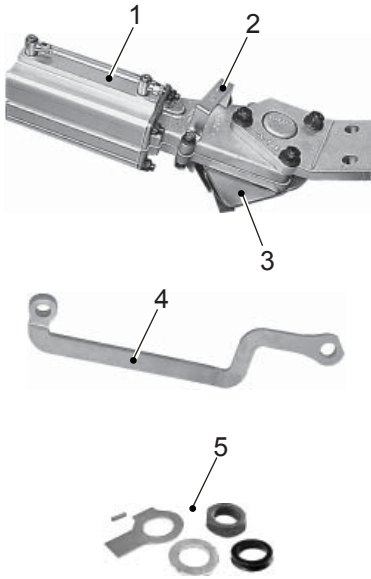
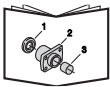

DE 56-244900 56-322001

Pos	Art.-nr	Bezeichnung	Anzahl	Pos	Det.nr	Bezeichnung	Anzahl
Onspotaggregat und Arm				Adapterplatten			
1	56-320501	Onspot-Aggregat links (Stanznummer 56-319000)	1	10a	56-244901	Adapterplatte links	1
	56-320502	Onspot-Aggregat rechts (Stanznummer 56-318900)	1	10b	56-244902	Adapterplatte rechts	1
2	56-320400	Schlauchhalter	2	11	56-109808	Doppelmuttern	8
3	56-320601	Stopper links, komplett (Stanznummer 56-318803)	1	12	35-018000	Schraube M16x40	8
	56-320602	Stopper rechts, komplett (Stanznummer 56-318804)	1	13	36-013100	Mutter M16	4
4	56-321015	Arm links inkl. pos. 5 (Stanznummer 56-321701)	1	14	37-000700	Scheibe 17x30x3	16
	56-321016	Arm rechts inkl. pos. 5 (Stanznummer 56-321702)	1	15	35-011500	Schraube M16x50	4
5	56-320700	Befestigungsteile für Arm	2				

Die VBG GROUP TRUCK EQUIPMENT AB behält sich das Recht auf Konstruktionsänderungen vor.

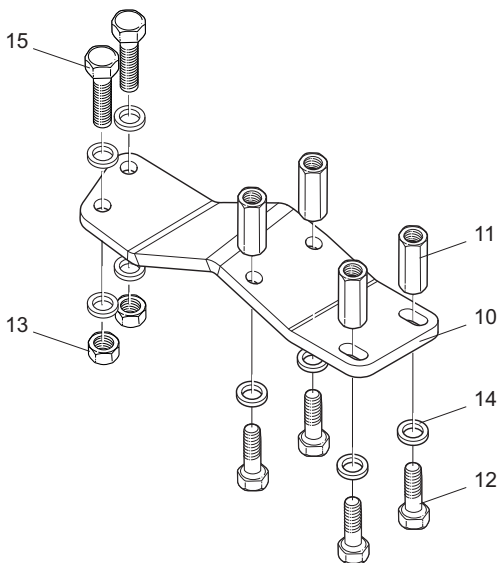
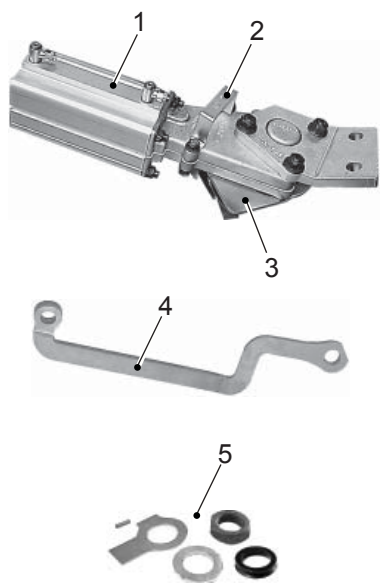

DK 56-244900 56-322001

Pos	Art.nr.	Betegnelse	Antal	Pos	Art.nr.	Betegnelse	Antal
		Onspotaggregat og arm				Konsol	
1	56-320501	Onspotaggregat venstre (ihugget nr. 56-319000)	1	10a	56-244901	Konsol venstre	1
	56-320502	Onspotaggregat højre (ihugget nr. 56-318900)	1	10b	56-244902	Konsol højre	1
2	56-320400	Slangeholder	2	11	56-109808	Dobbeltmøtrik	8
3	56-320601	Stop venstre, komplet (ihugget nr. 56-318803)	1	12	35-018000	Bolt M16x40	8
	56-320602	Stop højre, komplet (ihugget nr. 56-318804)	1	13	36-013100	Møtrik M16	4
4	56-321015	Arm venstre inkl. pos. 5 (ihugget nr. 56-321701)	1	14	37-000700	Skive 17x30x3	16
	56-321016	Arm højre inkl. pos. 5 (ihugget nr. 56-321702)	1	15	35-011500	Bolt M16x50	4
5	56-320700	Monteringsdele til arm	2				

VBG GROUP TRUCK EQUIPMENT AB forbeholder sig retten til konstruktionsændringer.

FI

56-244900 56-322001

Pos	Tuote no	Nimitys	Kpl	Pos	Tuote no	Nimitys	Kpl
Onspot-laite ja varsi				Autokiinnike			
1	56-320501	Vasen Onspot-laite (meistetty nro 56-319000)	1	10a	56-244901	Vasen autokiinnike	1
	56-320502	Oikea Onspot-laite (meistetty nro 56-318900)	1	10b	56-244902	Oikea autokiinnike	1
2	56-320400	Letkunkpidin	2	11	56-109808	Kaksoismutteri	8
3	56-320601	Vasen rajoitinasennelma (meistetty nro 56-318803)	1	12	35-018000	Ruuvi M16x40	8
	56-320602	Oikea rajoitinasennelma (meistetty nro 56-318804)	1	13	36-013100	Mutteri M16	4
4	56-321015	Vasen varsi sis. pos. 5 (meistetty nro 56-321701)	1	14	37-000700	Aluslevy 17x30x3	16
	56-321016	Oikea varsi sis. pos. 5 (meistetty nro 56-321702)	1	15	35-011500	Ruuvi M16x50	4
5	56-320700	Varren asennusosat	2				

VBG GROUP TRUCK EQUIPMENT AB pidättää oikeuden muuttaa rakennetta.

FR

56-244900 56-322001

Pos	N°d'art.	Désignation	Qté	Pos	N°d'art.	Désignation	Qté
Groupe Onspot et bras				Fixation voiture			
1	56-320501	Groupe Onspot gauche (No. 56-319000)	1	10a	56-244901	Fixation voiture gauche	1
	56-320502	Groupe Onspot droit (No. 56-318900)	1	10b	56-244902	Fixation voiture droit	1
2	56-320400	Support de tuyaux	2	11	56-109808	Écrou double	8
3	56-320601	Manivelle d'arrêt gauche complète (No. 56-318803)	1	12	35-018000	Vis M16x40	8
	56-320602	Manivelle d'arrêt droit complète (No. 56-318804)	1	13	36-013100	Écrou M16	4
4	56-321015	Bras gauche, avec pos. 5 (No. 56-321701)	1	14	37-000700	Rondelle 17x30x3	16
	56-321016	Bras droit, avec pos. 5 (No. 56-321702)	1	15	35-011500	Vis M16x50	4
5	56-320700	Éléments de fixation du bras	2				

VBG GROUP TRUCK EQUIPMENT AB se réserve le droit de modifier ses constructions.

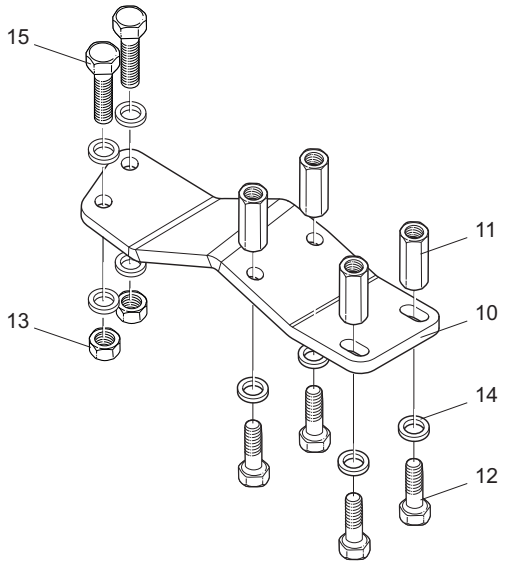
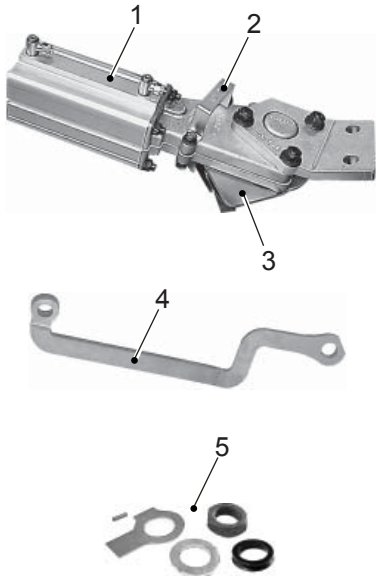

GB 56-244900 56-322001

Pos	Part no.	Description	Qty	Pos	Part no.	Description	Qty
Onspot-unit and arm				Vehicle bracket			
1	56-320501	Onspot unit left (stamped no. 56-319000)	1	10a	56-244901	Vehicle bracket left	1
	56-320502	Onspot unit right (stamped no. 56-318900)	1	10b	56-244902	Vehicle bracket right	1
2	56-320400	Hose holder	2	11	56-109808	Double nut	8
3	56-320601	Stop knob left, complete (stamped no. 56-318803)	1	12	35-018000	Screw M16x40	8
	56-320602	Stop knob right, complete (stamped no. 56-318804)	1	13	36-013100	Nut M16	4
4	56-321015	Arm left, incl. pos. 5 (stamped no. 56-321701)	1	14	37-000700	Washer 17x30x3	16
	56-321016	Arm right, incl. pos. 5 (stamped no. 56-321702)	1	15	35-011500	Screw M16x50	4
5	56-320700	Arm fasteners	2				

VBG GROUP TRUCK EQUIPMENT AB reserve the right to amend or alter specifications at their discretion.

IT

56-244900 56-322001

Pos.	Codice	Descrizione	Q	Pos.	Codice	Descrizione	Q
		Unità Onspot e braccio				Staffe per montaggio al veicolo	
1	56-320501	Unità Onspot sinistra (n°identificativo 56-319000)	1	10a	56-244901	Staffa sinistra	1
	56-320502	Unità Onspot destra (n°identificativo 56-318900)	1	10b	56-244902	Staffa destra	1
2	56-320400	Supporto del flessibile	2	11	56-109808	Dado doppio	8
3	56-320601	Manovella d'arresto sinistra, completa (n°identificativo 56-318803)	1	12	35-018000	Vite M16x40	8
	56-320602	Manovella d'arresto destra, completa (n°identificativo 56-318804)	1	13	36-013100	Dado M16	4
4	56-321015	Braccio sinistro, incl. pos. 5 (n°identificativo 56-321701)	1	14	37-000700	Rondella 17x30x3	16
	56-321016	Braccio destro, incl. pos. 5 (n°identificativo 56-321702)	1	15	35-011500	Vite M16x50	4
5	56-320700	Elementi di fissaggio del braccio	2				

VBG GROUP TRUCK EQUIPMENT AB si riserva il diritto di modifica senza preavviso.

LV

56-244900 56-322001

Pozīcija	Det.nr.	Nosaukums	Skaits	Pozīcija	Det.nr.	Nosaukums	Skaits
		OnSpot agregāts un svira				Automašīnas kronšteins	
1	56-320501	OnSpot agregāts, kreisais (marķējuma № 56-319000)	1	10a	56-244901	Automašīnas kronšteins, kreisais	1
	56-320502	OnSpot agregāts, labais (marķējuma № 56-318900)	1	10b	56-244902	Automašīnas kronšteins, labais	1
2	56-320400	Šļūtenes turētājs	2	11	56-109808	Dubultuzgrieznis	8
3	56-320601	Izslēgšanas poga, kreisā, komplekts, (marķējuma № 56-318803)	1	12	35-018000	Skrūve M16x40	8
	56-320602	Izslēgšanas poga, labā, komplekts, (marķējuma № 56-318804)	1	13	36-013100	Uzgrieznis M16	4
4	56-321015	Svira, kreisā, iesk. poz. 5 (marķējuma № 56-321701)	1	14	37-000700	Paplāksne 17x30x3	16
	56-321016	Svira, labā, iesk. poz. 5 (marķējuma № 56-321702)	1	15	35-011500	Skrūve M16x50	4
5	56-320700	Sviru stiprinājumi	2				

VBG GROUP TRUCK EQUIPMENT AB saglabā tiesības izdarīt izmaiņas izstrādājumu konstrukcijās.

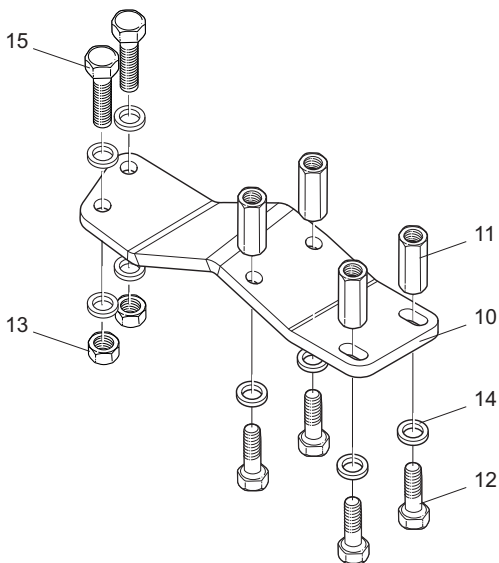
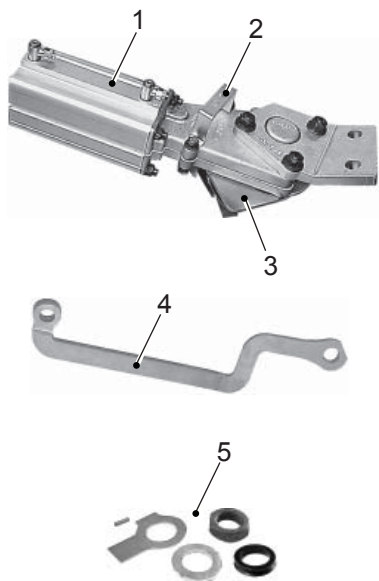

NO 56-244900 56-322001

Pos	Art.nr	Navn	Antall	Pos	Art.nr	Navn	Antall
Onspotaggregat og arm				Bilfeste			
1	56-320501	Onspot-aggregat venstre (identifikasjonsnr 56-319000)	1	10a	56-244901	Bilfeste venstre	1
	56-320502	Onspot-aggregat høyre (identifikasjonsnr 56-318900)	1	10b	56-244902	Bilfeste høyre	1
2	56-320400	Slangeholder	2	11	56-109808	Dobbeltmutter	8
3	56-320601	Stopperatt venstre, komplett (identifikasjonsnr 56-318803)	1	12	35-018000	Skrue M16x40	8
	56-320602	Stopperatt høyre, komplett (identifikasjonsnr 56-318804)	1	13	36-013100	Mutter M16	4
4	56-321015	Arm venstre inkl. pos. 5 (identifikasjonsnr 56-321701)	1	14	37-000700	Skive 17x30x3	16
	56-321016	Arm høyre inkl. pos. 5 (identifikasjonsnr 56-321702)	1	15	35-011500	Skrue M16x50	4
5	56-320700	Fstedetaljer for arm	2				

VBG GROUP TRUCK EQUIPMENT AB forbeholder seg retten til konstruksjonsendringer.

PL

56-244900 56-322001

Poz.	Nr części	Nazwa	Ilość	Poz.	Nr części	Nazwa	Ilość
Urządzenie Onspot i ramię				Zamocowanie do pojazdu			
1	56-320501	Urządzenie Onspot strona lewa (wybity numer 56-319000)	1	10a	56-244901	Zamocowanie do pojazdu, lewe	1
	56-320502	Urządzenie Onspot strona prawa (wybity numer 56-318900)	1	10b	56-244902	Zamocowanie do pojazdu, prawe	1
2	56-320400	Uchwyt przewodu giętkiego	2	11	56-109808	Nakrętka podwójna	8
3	56-320601	Pokrętko oporowe lewe, komplet (wybity numer 56-318803)	1	12	35-018000	Śruba M16x40	8
	56-320602	Pokrętko oporowe prawo, komplet (wybity numer 56-318804)	1	13	36-013100	Nakrętka M16	4
4	56-321015	Ramię lewe, włącznik z poz. 5 (wybity numer 56-321701)	1	14	37-000700	Podkładka 17x30x3	16
	56-321016	Ramię prawo, włącznik z poz. 5 (wybity numer 56-321702)	1	15	35-011500	Śruba M16x50	4
5	56-320700	Elementy mocujące ramienia	2				

VBG GROUP TRUCK EQUIPMENT AB zastrzega sobie prawo wprowadzania zmian produktów bez uprzedzenia.

SE

56-244900 56-322001

Pos	Det.nr	Benämning	Antal	Pos	Det.nr	Benämning	Antal
Onspotaggregat och arm				Bilfäste			
1	56-320501	Onspotaggregat vänster (instansat nr 56-319000)	1	10a	56-244901	Bilfäste VF	1
	56-320502	Onspotaggregat höger (instansat nr 56-318900)	1	10b	56-244902	Bilfäste HF	1
2	56-320400	Slanghållare	2	11	56-109808	Dubbelmutter	8
3	56-320601	Stoppvred vänster, komplett (instansat nr 56-318803)	1	12	35-018000	Skruv M16x40	8
	56-320602	Stoppvred höger, komplett (instansat nr 56-318804)	1	13	36-013100	Mutter M16	4
4	56-321015	Arm vänster inkl. pos. 5 (instansat nr 56-321701)	1	14	37-000700	Bricka 17x30x3	16
	56-321016	Arm höger inkl. pos. 5 (instansat nr 56-321702)	1	15	35-011500	Skruv M16x50	4
5	56-320700	Fästdetaljer för arm	2				

VBG GROUP TRUCK EQUIPMENT AB förbehåller sig rätten till konstruktionsförändringar.

AUSTRALIA

TRANSPREC LIMITED
P O Box 217 1 Cherry Lane
AU - 3028 P.O LAVERTON, VIC 3028
Tel +61 3 92 67 24 44
Fax +61 3 93 69 48 26

BELGIUM/LUXEMBOURG

WABCO Belgium S.A. - N.V.
Petrus Bayensstraat 70
BE - 1702 GROOT-BIJGAARDEN
Tel +32 248 10900
Fax +32 24633659

DENMARK

VBG GROUP SALES A/S
Industribuen 20-22
DK - 5592 EJBY
Tel +45 6446 1919
Fax +45 6446 1088

ESTONIA

GOKART AS
Peterburi tee 111
EE-11415 TALLINN
Tel +372 623 0622
Faks +372 623 0621

FINLAND

H KRAATZ OY
Ruukimestarintie 9
FI - 02330 ESPOO
Tel +358 9 8093100
Fax +358 9 80931099

FRANCE

ONSPOT Sàrl
14 Route de Sarrebruck
FR - 57645 MONTROY-FLANVILLE
Tel +33 3 8776 3080
Fax +33 3 8776 1944

GERMANY

VBG GROUP TRUCK EQUIPMENT GMBH
Oberschlesienstrasse 15
DE - 47807 KREFELD
Tel +49 2151 835 0
Fax +49 2151 835 200

GREAT BRITAIN

VBG GROUP SALES LIMITED
Unit 9 Willow Court
West Quay Road
Winwick Quay
Warrington
Cheshire WA2 8UF
Tel +44 1925 234111
Fax +44 1925 234222

ICELAND

OSAL OSKAR ANDERSSON
Tangarhofdi 4
IS - 110 REYKJAVIK
Tel +354 587 6619
Fax +354 187 7719

IRELAND

NEWBRIDGE METALS PRODUCTS LTD
Newbridge Industrial Estate
IE - NEWBRIDGE, County Kildare, Eire
Tel +353 45 431 502
Fax +353 45 433 747

ISRAEL

H KLEIN & SONS LTD
P O Box 1093
Industrial Area-North
IL - ASHDOD 77109
Tel +972 8856 4330
Fax +972 8856 4324

ITALY

MAGGI CANTENE S.P.A
Via Milano 2/4
I- 23854 Olginate
ITALY
Tel +39 0341 60 52 35
Fax +39 0341 60 53 52

JAPAN

SHINKO BOEKI CO LTD
Shibuya Central Bldg
3-14 Udagawa-cho, Shibuya-ku,
JP - TOKYO 150
Tel +81 3 33463 0941
Fax +81 3 33463 1707

NETHERLANDS

WABCO AUTOMOTIVE B.V.
Postbus 8704
NL - 3009 AS ROTTERDAM
Tel +31 10 2888 600
Fax +31 10 2888 601

NEW ZEALAND

TRANSPORT SPECIALTIES LTD
P O BOX 98-971
NZ - S.A.M.C., Wiri, AUCKLAND
Tel +64 9 980 7300
Fax +64 9 980 7306

NORWAY

VBG GROUP SALES AS
Postboks 94 Leirdal
NO - 1009 OSLO
Tel +47 23 14 16 60
Fax +47 23 14 16 61

POLAND

HYVA POLSKA Sp. z o.o.
ul. Myśliwska 68
PL - 30718 KRAKÓW
Tel +48 12 658 65 05
Fax +48 12 658 44 39

SOUTH AFRICA

TRANSPORT TECHNOLOGY
Greenside 2034
ZA - 1450 JOHANNESBURG
Tel +27 11 7810491
Fax +27 11 7894441

SWEDEN

VBG GROUP TRUCK EQUIPMENT AB
Box 1216
SE - 462 28 VÄNERSBORG
Tel +46 521 277700
Fax +46 521 277795

Branch office:

VBG GROUP TRUCK EQUIPMENT AB
Umestans Företagspark Hus 2
SE - 903 47 UMEA
Tel +46 90 271 10
Fax +46 90 326 11

SWITZERLAND

AGL für LASTWAGENZUBEHÖRE
Postfach
CH - 6048 HORW
Tel +41 41 340 25 25
Fax +41 41 340 31 79

SWITZERLAND

AMBOFIX METALLBAU
U. Ambühl
Am Schachenrain 36
CH - 4562 BIBERIST
Tel +41 32 6 72 36 83
Fax +41 32 67 22 267

TANZANIA

SUPERDOLL TRAILERS MANUFACTURE CO. LTD
P.O Box 16541
TZ - DAR ES SALAAM
Tel +255 22 2860930
Fax +255 22 2865412

VBG GROUP TRUCK EQUIPMENT AB

Herman Kreftings gata 4
Box 1216
SE-462 28 VÄNERSBORG
Tel +46 521 27 77 00
E-mail info@vbg.se
www.vbg.se