

# Mounting instructions

2010-10-20 38-186200b

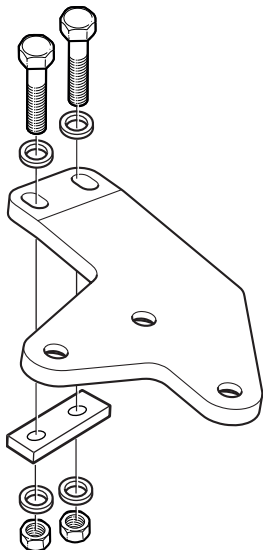

Iveco  
Eurocargo ML 90 E 21 /FP  
56-245900  
56-320000

**DE** 2-Balg-Luftfederung

**DK** Luftaffjedring med 2 bælg

**FI** 2-palkeen ilmajousitus

**FR** Suspension pneu à 2 soufflets

**GB** 2 belowses air suspension

**IT** Sospensioni pneumatiche a 2 soffiatti



**LV** 2 plēšu amortizators pneimatiskais

**NO** 2-belgs luftfjæring

**PL** Resorowanie pneumatyczne

**SE** 2-bälgs luftfjädring

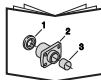
**ONSPOT**

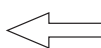
	Montageanleitung Monteringvejledning Asennusohje	Instructions de montage Mounting instruction Istruzioni di montaggio	Montāžas instrukcija Monteringsanvisning Instrukcja montażowa Monteringsanvisning
	Ersatzteilliste Reservedeliste Varaosaluettelo	Liste des pièces détachées Spare Parts List Parti di ricambio	Rezerves daļu saraksts Reservedelliste Lista czæúci zamiennych Reservdelista
	Anleitungen des Herstellers Producentens anvisning Valmistajan ohjeet	Instructions du fabricant Manufacturer's instruction Istruzioni del produttore	Ražotāja norādījumi Produsentens anvisning Wskazówki producenta Tillverkarens anvisning
	Anweisungen des LKW-Herstellers Lastbilfabrikantens anvisning Ajoneuvon valmistajan ohjeet Instruction du constructeur Vehicle manufacture instruction	Istruzioni del produttore del carrello Autorūpņicas instrukcija Lastebilproduzentens anvisning Instrukcja producenta pojazdu Lastvagnstillverkarens anvisning	
	Fahrtrichtung Kørselsretning Ajosuunta	Sens de conduite Direction of travel Senso di marcia	Kustības virziens Kjøreretning Kierunek jazdy Färdriktning

## **Allgemein**

Die Montage darf nur von ausgebildetem und kompetentem Fachpersonal durchgeführt werden und muß in einer befugten Werkstatt erfolgen, die über erforderliche Werkzeuge und Ausrüstungen verfügt, und in der Zugänglichkeit und Sicherheit gegeben sind. Alle Teile vor der Montage identifizieren. Anweisungen befolgen.

Empfohlene Einstellungen nicht ändern. Übergeben Sie dem Kunden alle Anweisungen und Instruktionen zur Aufbewahrung im Fahrzeug für künftige Service- und Wartungsarbeiten.

 Befolgen Sie die Anweisungen des LKW-Herstellers

## **Generelt**

Monteringen skal foretages af uddannet og kompetent personale og ske på autoriseret værksted, der råder over det nødvendige værktøj og udstyr, og hvor der sikres tilgængelighed og sikkerhed. Kontroller at alle dele er til stede inden montering. Følg anvisningerne.

Anbefalede indstillinger må ikke ændres. Giv kunden alle anvisninger og instruktioner, så de kan lægges i bilen til brug ved fremtidig service og vedligeholdelse.

 Følg lastbilfabrikantens anvisninger



## Yleistä

Laitteisto on asennettava valtuutetussa korjaamossa, jonka koulutetulla ja ammattitaitoisella henkilökunnalla on käytössään tarvittavat työkalut ja varusteet ja jossa on turvalliset työskentelyolot. Tunnista kaikki osat ennen asennusta. Noudata ohjeita.

Älä muuta suositeltuja säätöjä. Luovuta kaikki ohjeet asiakkaalle säilytettäväksi autossa tulevia huoltoja ja kunnossapitoa varten.



Noudata ajoneuvon valmistajan ohjeita



## Généralités

Le montage doit être effectué par des personnes possédant la compétence et la formation requises, dans un atelier autorisé disposant des outils et équipements nécessaires et où l'accessibilité et la sécurité peuvent être assurées. Identifier tous les composants avant de procéder au montage. Suivre les instructions.

Ne pas modifier les réglages recommandés. Toutes les informations et toutes les instructions doivent être remises au client afin d'être conservées dans le véhicule et utilisées pour les opérations d'entretien futures.



Se conformer également aux instructions du constructeur du camion



## General

Installation work should be carried out by trained and skilled staff. It should be performed at an authorised workshop where the required tools and equipment are available and where provisions can be made for accessibility and safety. Identify all components prior to installation. Follow the instructions.

Do not alter the recommended settings. Give the customer all directives and instructions so that these can be kept in the vehicle for future service and maintenance.



Follow the instructions of the vehicle manufacturer



## Generalità

Il montaggio deve essere effettuato da personale competente e dotato della formazione richiesta, in una officina autorizzata, in possesso delle necessarie attrezzature e dove accessibilità e sicurezza possano essere garantite. Identificare tutti i componenti prima di procedere al montaggio. Seguire le istruzioni.

Non modificarne le raccomandazioni. Tutte le informazioni e tutte le istruzioni devono essere trasmesse al cliente e conservate a corredo del veicolo per essere utilizzate nelle operazioni di successiva manutenzione.



Attenersi altresì alle istruzioni del costruttore del veicolo.



## Vispārēji norādījumi

Uzstādīšanas darbi jāveic trenētām un apmācītam personālam. Tie jāizpilda autorizētā darbnīcā, kur ir pieejami nepieciešamie darbarīki un aprīkojums un kur ir nepieciešamie nosacījumi, lai nodrošinātu piekļuvi un drošību. Pirms montāžas identificējiet visas detaļas. Sekojiet norādījumiem. Neizmainiet ieteiktos iestatījumus. Visus norādījumus un instrukcijas izsniedziet klientam, lai tās tiktu uzglabātas automobilī un būtu pieejamas servisa un apkopes gadījumos.



Ievērojiet automašīnas izgatavotāja instrukcijas.



## Generelt

Monteringen skal utføres av kompetent personell med nød-vendig opplæring, og skal skje på autorisert verksted hvor nødvendig verktøy og utstyr er tilgjengelig og sikkerheten kan ivaretas. Identifiser alle deler før montering. Følg anvisningene.

Ikke foreta endringer av anbefalte innstillinger. Overlever alle anvisninger og instruksjoner til kunden for oppbevaring i kjøretøyet for fremtidig service og vedlikehold.



Følg lastebilprodusentens anvisninger



## Informacje ogólne

Montaż powinien być wykonywany wyłącznie przez przeszkolonych i kompetentnych pracowników. Powinien być wykonany w autoryzowanym punkcie obsługi technicznej, gdzie znajdują się wymagane narzędzia i wyposażenie oraz gdzie może być zapewniony odpowiedni dostęp i bezpieczeństwo. Zapoznaj się z poszczególnymi częściami przed przystąpieniem do montażu. Stosuj się do instrukcji. Nie zmieniaj zalecanych ustawień. Wszystkie wskazówki i instrukcje należy przekazać klientowi w celu przechowywania ich w pojeździe i wykorzystywania przy okazji przyszłych czynności serwisowych i konserwacyjnych.



Postępuj zgodnie z instrukcją producenta pojazdu.



## Allmänt

Monteringen skall utföras av utbildad och kompetent personal och ske på auktoriserad verkstad där erforderliga verktyg och utrustning finns och där åtkomlighet och säkerhet kan tillgodoses. Identifiera alla delar före montering. Följ anvisningarna.

Ändra ej rekommenderade inställningar. Lämna alla anvisningar och instruktioner till kunden att förvaras i fordonet för framtida service och underhåll.



Följ lastvagnstillverkarens anvisningar

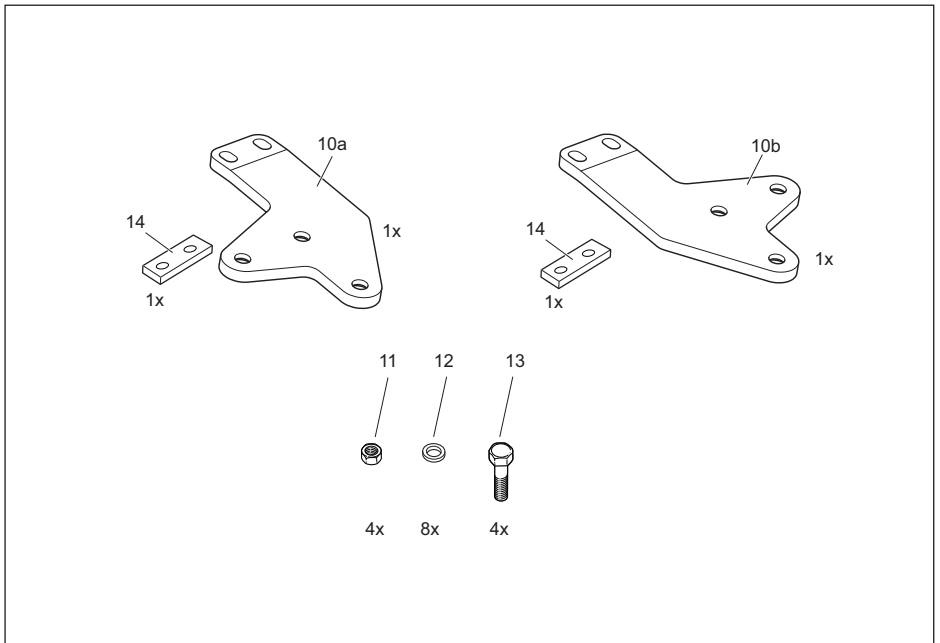
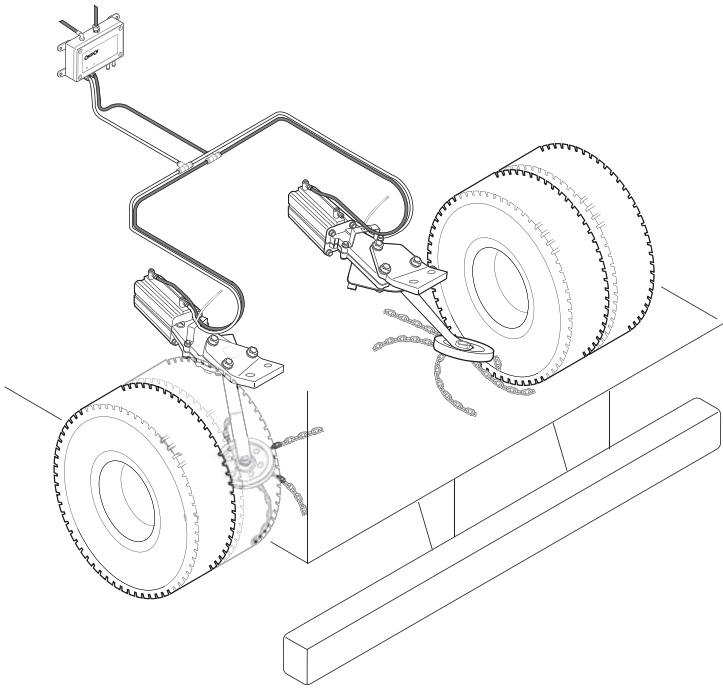

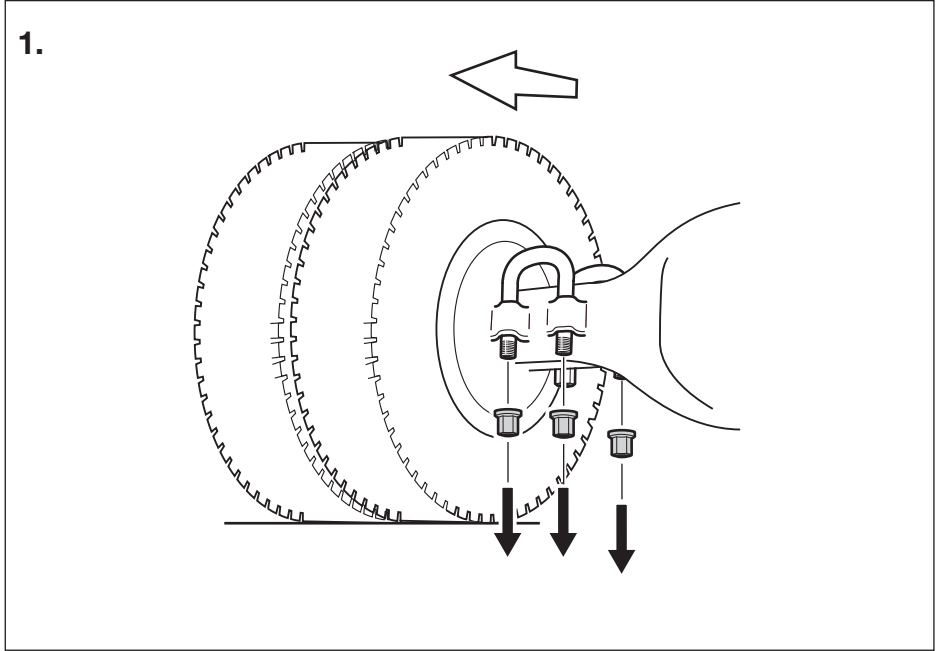
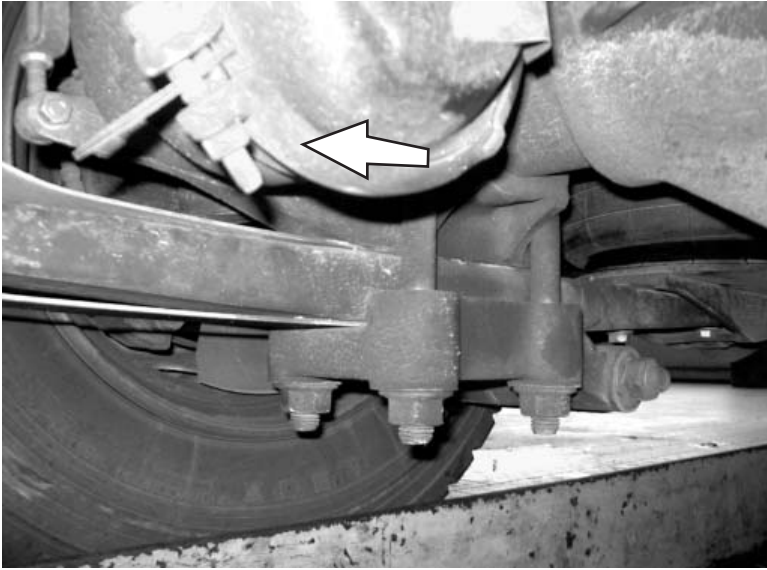

2.

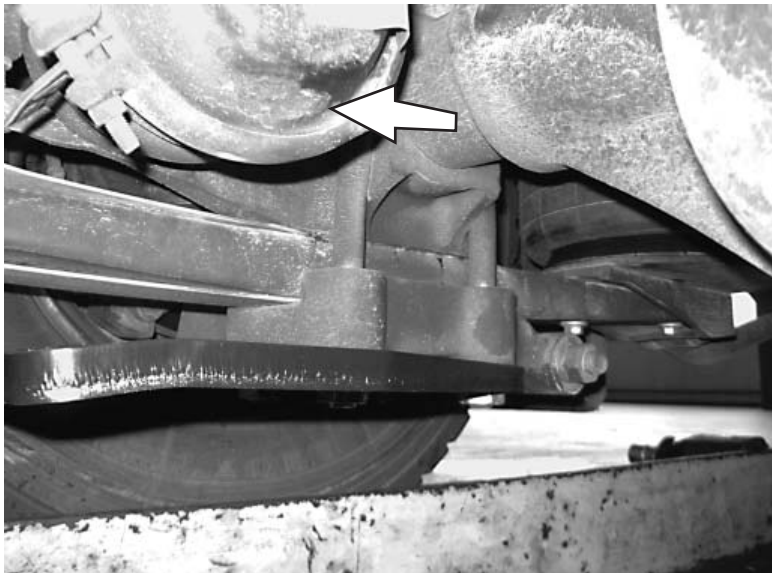
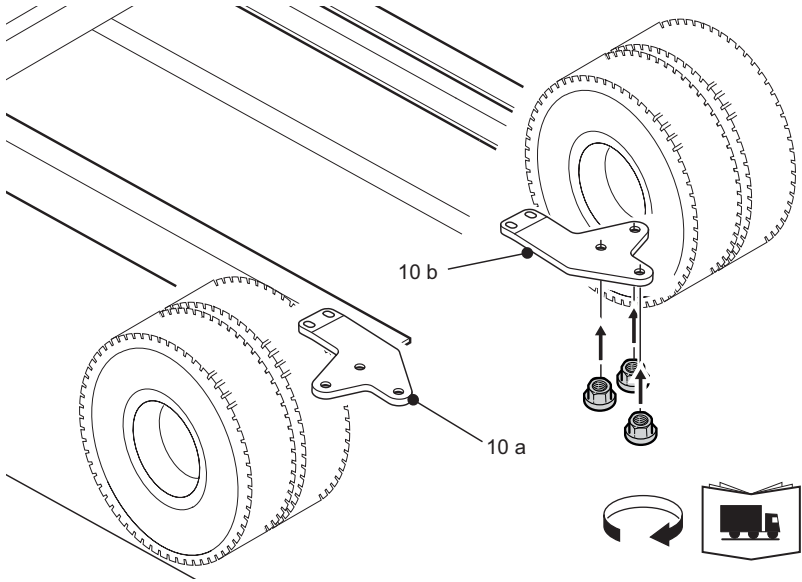

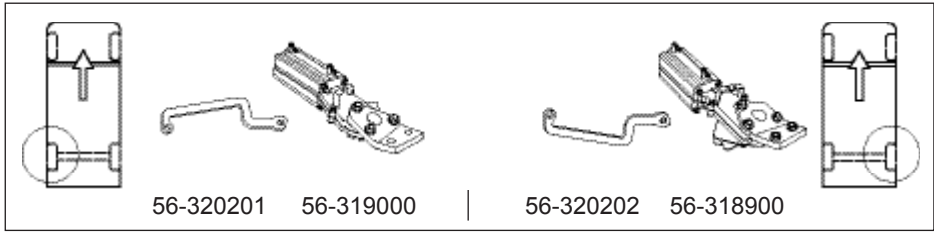

3a.

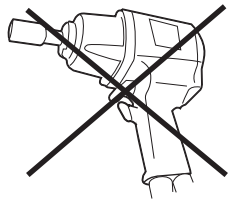
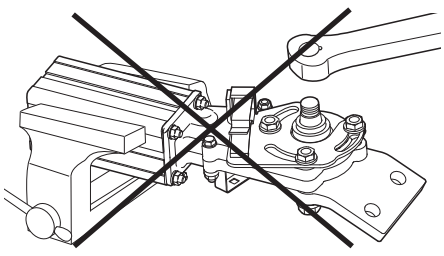
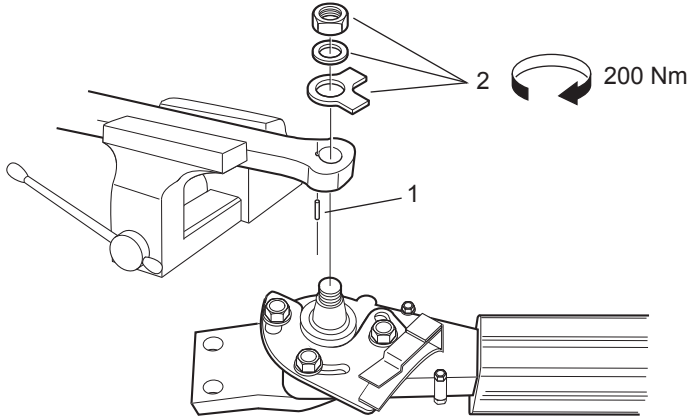

3b.

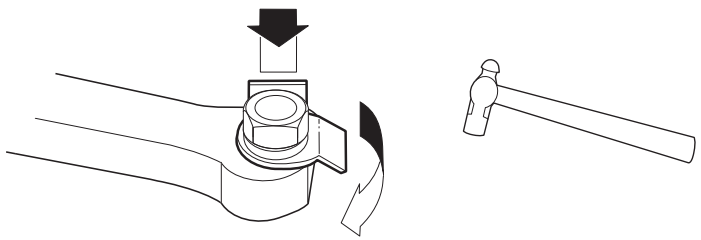



7.

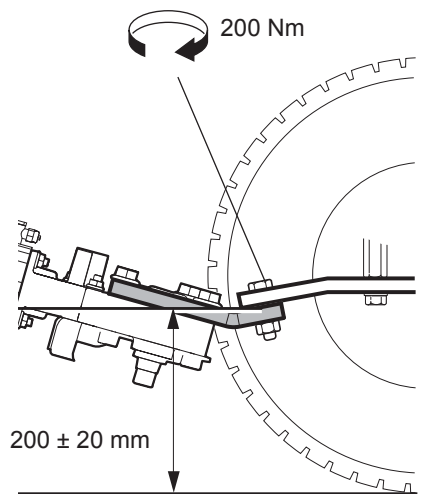
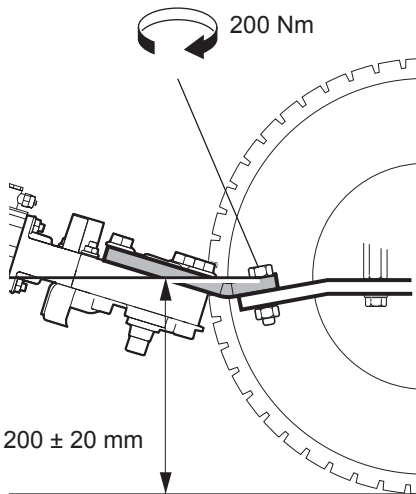

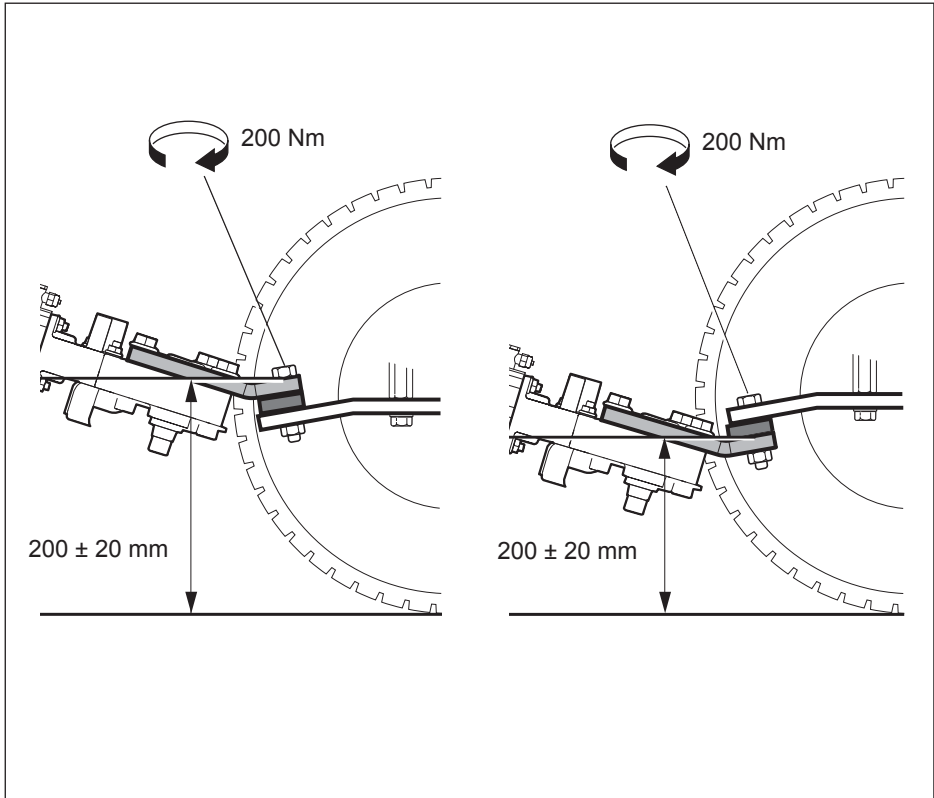

8.



38-155900

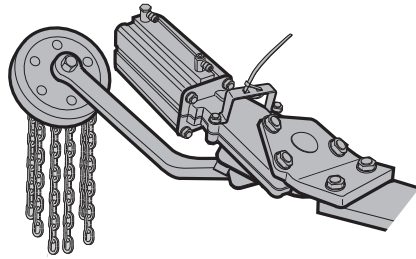

9.

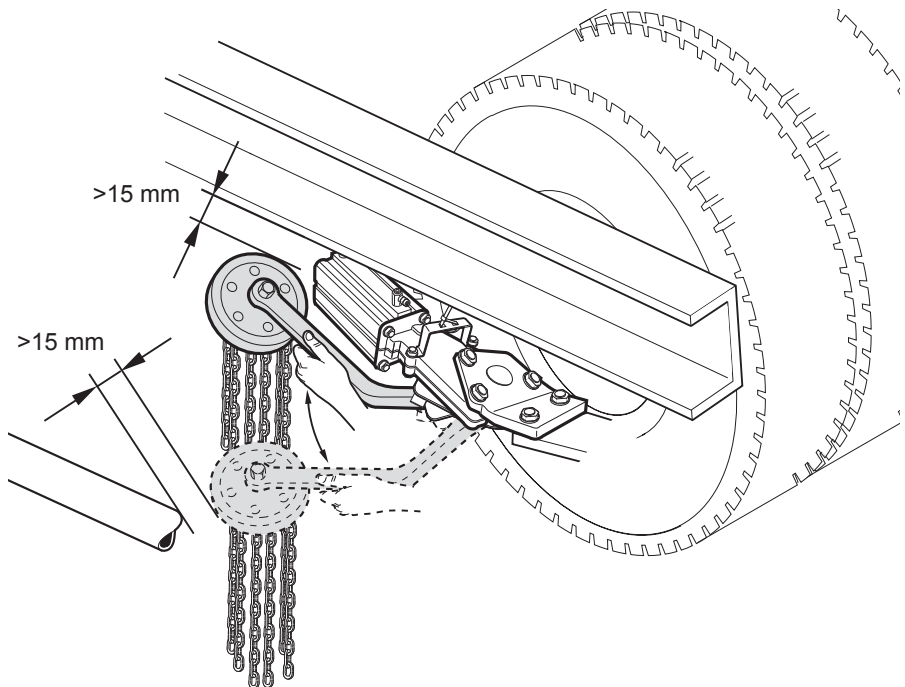

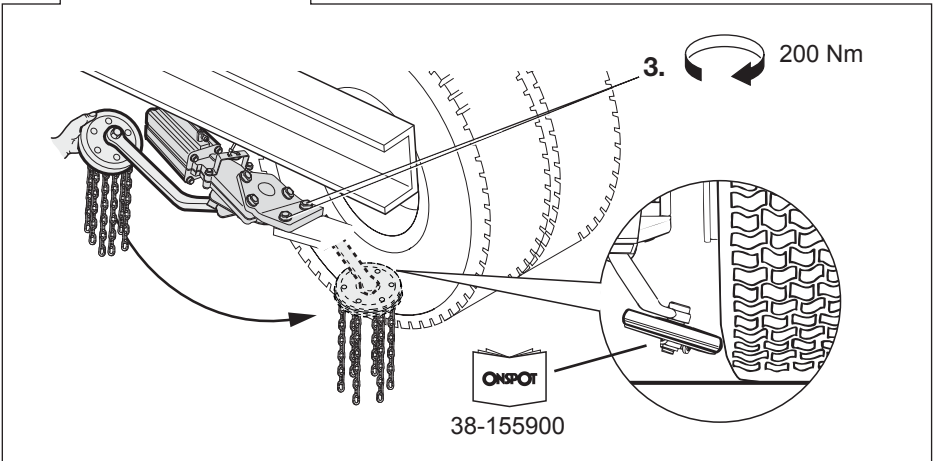
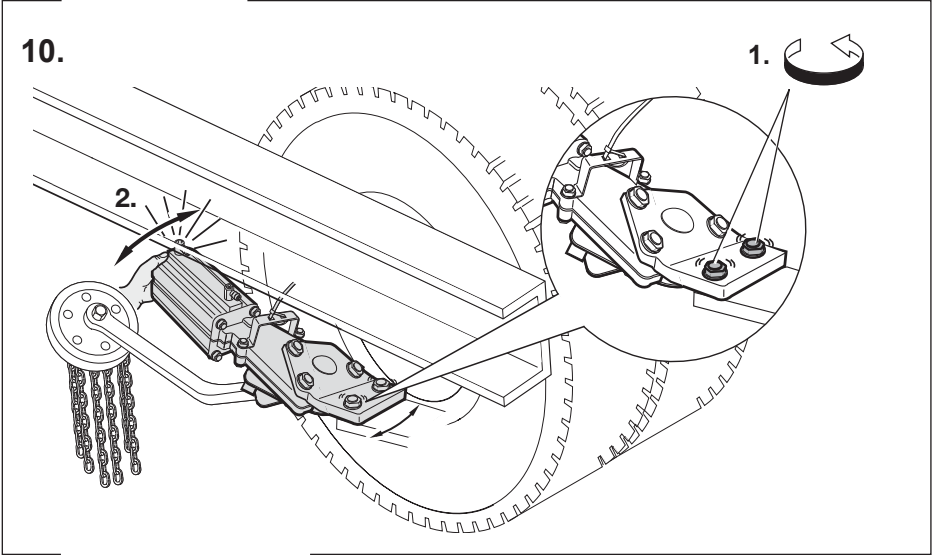
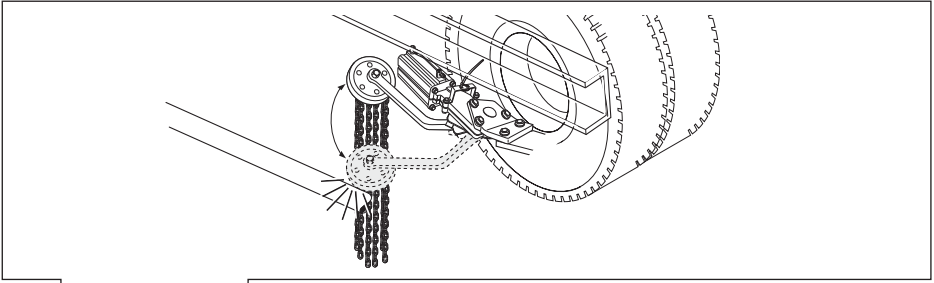

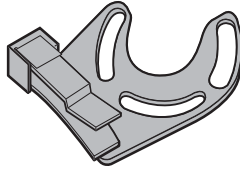

11.

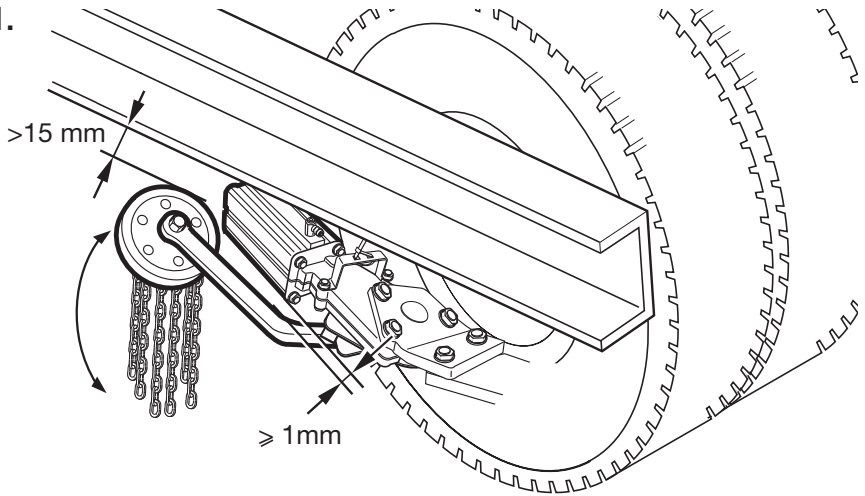

12.

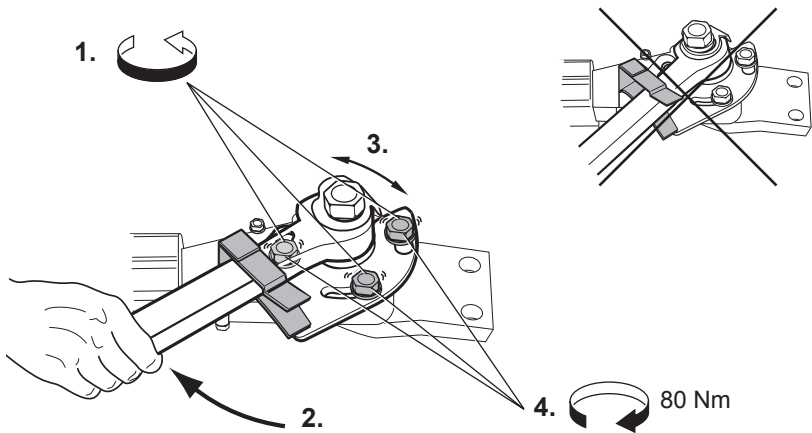

13.

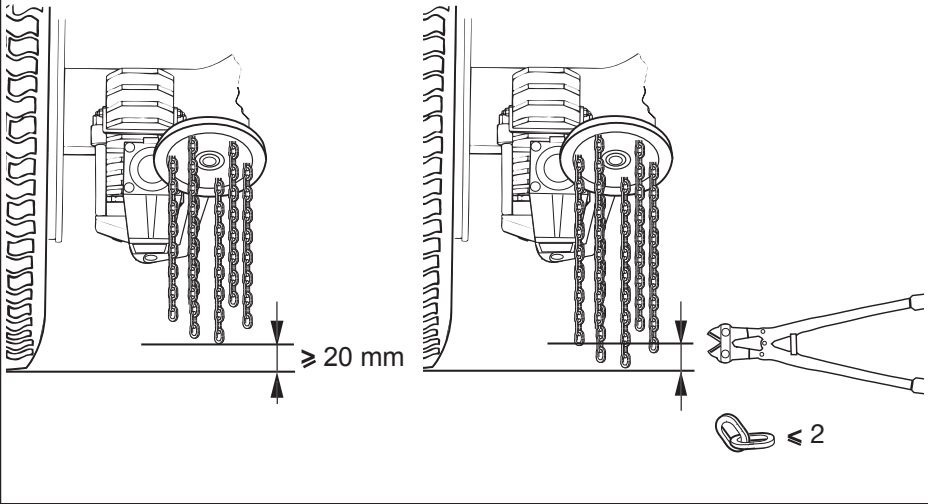

14.

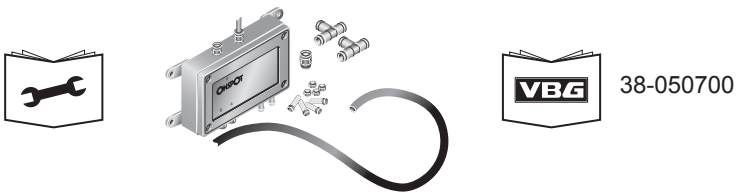

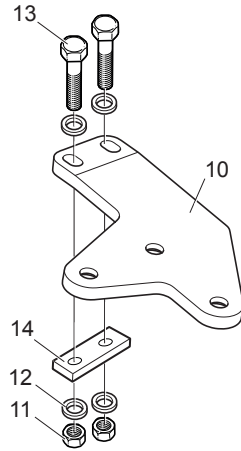
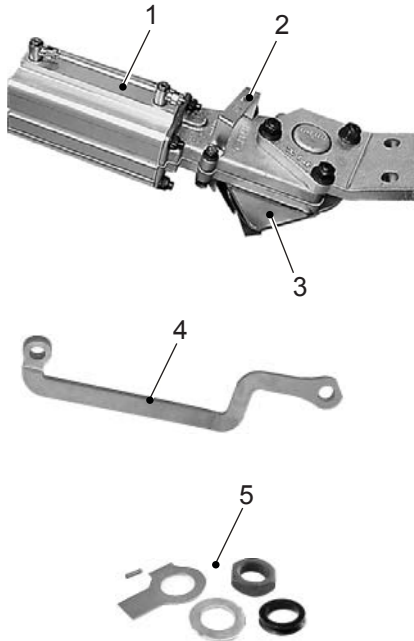
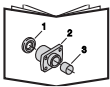

**DE 56-245900 56-320000**

Pos	Art.-nr	Bezeichnung	Anzahl	Pos	Art.-nr	Bezeichnung	Anzahl
<b>Onspotaggregat und Arm</b>				<b>Adapterplatten</b>			
1	56-320501	Onspot-Aggregat links (Stanznummer 56-319000)	1	10a	56-245901	Adapterplatte links	1
	56-320502	Onspot-Aggregat rechts (Stanznummer 56-318900)	1	10b	56-245902	Adapterplatte rechts	1
2	56-320400	Schlauchhalter	2	11	36-013100	Mutter M16 nylock	4
3	56-320601	Stopper links, komplett (Stanznummer 56-318803)	1	12	37-000700	Scheibe 17x30x3	8
	56-320602	Stopper rechts, komplett (Stanznummer 56-318804)	1	13	35-033500	Schraube M16x70	4
4	56-321001	Arm links inkl. pos. 5 (Stanznummer 56-320201)	1	14	56-193700	Distanzplatte	2
	56-321002	Arm rechts inkl. pos. 5 (Stanznummer 56-320202)	1				
5	56-320700	Befestigungsteile für Arm	2				

Die VBG PRODUKTER AB behält sich das Recht auf Konstruktionsänderungen vor.

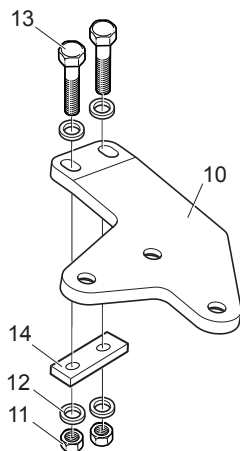
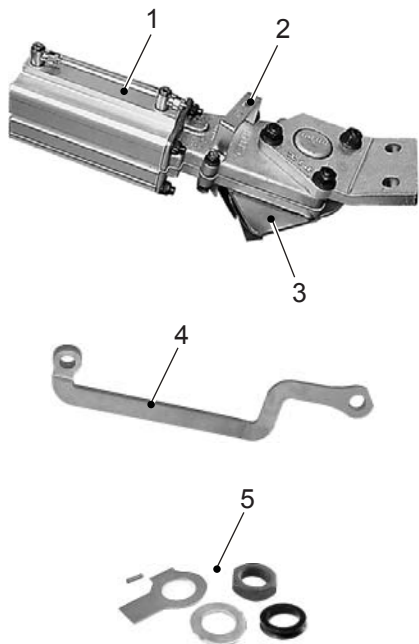

**DK 56-245900 56-320000**

Pos	Art..nr.	Betegnelse	Antal	Pos	Art.nr.	Betegnelse	Antal
		<b>Onspotaggregat og arm</b>				<b>Konsol</b>	
1	56-320501	Onspotaggregat venstre (ihugget nr. 56-319000)	1	10a	56-245901	Konsol venstre	1
	56-320502	Onspotaggregat højre (ihugget nr. 56-318900)	1	10b	56-245902	Konsol højre	1
2	56-320400	Slangeholder	2	11	36-013100	Møtrik M16 nylock	4
3	56-320601	Stop venstre, komplet (ihugget nr. 56-318803)	1	12	37-000700	Skive 17x30x3	8
	56-320602	Stop højre, komplet (ihugget nr. 56-318804)	1	13	35-033500	Bolt M16x70	4
4	56-321001	Arm venstre inkl. pos. 5 (ihugget nr. 56-320201)	1	14	56-193700	Avstandsplade	2
	56-321002	Arm højre inkl. pos. 5 (ihugget nr. 56-320202)	1				
5	56-320700	Monteringsdele til arm	2				

VBG PRODUKTER AB forbeholder sig retten til konstruktionsændringer.



FI

**56-245900 56-320000**

Pos	Tuote no	Nimitys	Kpl	Pos	Tuote no	Nimitys	Kpl
<b>Onspot-laite ja varsi</b>				<b>Autokiinnike</b>			
1	56-320501	Vasen Onspot-laite (meistetty nro 56-319000)	1	10a	56-245901	Vasen autokiinnike	1
	56-320502	Oikea Onspot-laite (meistetty nro 56-318900)	1	10b	56-245902	Oikea autokiinnike	1
2	56-320400	Letkupidin	2	11	36-013100	Mutteri M16 nylock	4
3	56-320601	Vasen rajoitinasennelma (meistetty nro 56-318803)	1	12	37-000700	Aluslevy 17x30x3	8
	56-320602	Oikea rajoitinasennelma (meistetty nro 56-318804)	1	13	35-033500	Pultti M16x70	4
4	56-321001	Vasen varsi sis. pos. 5 (meistetty nro 56-320201)	1	14	56-193700	Välilevy	2
	56-321002	Oikea varsi sis. pos. 5 (meistetty nro 56-320202)	1				
5	56-320700	Varren asennusosat	2				

VBG PRODUKTER AB pidättää oikeuden muuttaa rakennetta

FR

**56-245900 56-320000**

Pos	N°d'art.	Désignation	Qté	Pos	N°d'art.	Désignation	Qté
<b>Groupe Onspot et bras</b>				<b>Fixation voiture</b>			
1	56-320501	Groupe Onspot gauche (No. 56-319000)	1	10a	56-245901	Fixation voiture gauche	1
	56-320502	Groupe Onspot droit (No. 56-318900)	1	10b	56-245902	Fixation voiture droite	1
2	56-320400	Support de tuyaux	2	11	36-013100	Écrou M16 nylock	4
3	56-320601	Manivelle d'arrêt gauche complète (No. 56-318803)	1	12	37-000700	Rondelle 17x30x3	8
	56-320602	Manivelle d'arrêt droite complète (No. 56-318804)	1	13	35-033500	Vis M16x70	4
4	56-321001	Bras gauche, avec pos. 5 (No. 56-320201)	1	14	56-193700	Tôle entretoise	2
	56-321002	Bras droit, avec pos. 5 (No. 56-320202)	1				
5	56-320700	Éléments de fixation du bras	2				

VBG PRODUKTER AB se réserve le droit de modifier ses constructions.

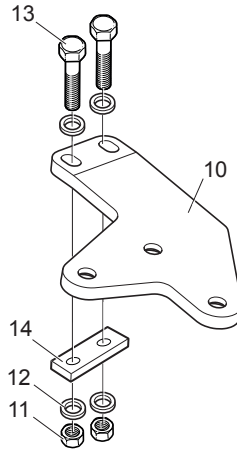
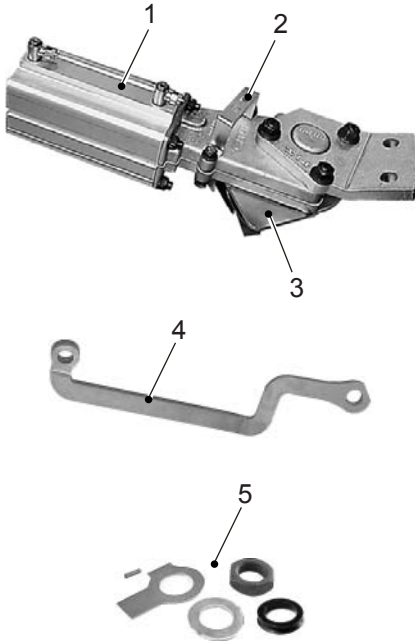

**GB 56-245900 56-320000**

Pos	Part no.	Description	Qty	Pos	Part no.	Description	Qty
<b>Onspot-unit and arm</b>				<b>Vehicle bracket</b>			
1	56-320501	Onspot unit left (stamped no. 56-319000)	1	10a	56-245901	Vehicle bracket, left	1
	56-320502	Onspot unit right (stamped no. 56-318900)	1	10b	56-245902	Vehicle bracket, right	1
2	56-320400	Hose holder	2	11	36-013100	Nut M16 nylock	4
3	56-320601	Stop knob left, complete (stamped no. 56-318803)	1	12	37-000700	Washer 17x30x3	8
	56-320602	Stop knob right, complete (stamped no. 56-318804)	1	13	35-033500	Screw M16x70	4
4	56-321001	Arm left, incl. pos. 5 (stamped no. 56-320201)	1	14	56-193700	Spacing plate	2
	56-321002	Arm right, incl. pos. 5 (stamped no. 56-320202)	1				
5	56-320700	Arm fasteners	2				

VBG PRODUKTER AB reserve the right to amend or alter specifications at their discretion.

IT

**56-245900 56-320000**

Pos.	Codice	Descrizione	Q	Pos.	Codice	Descrizione	Q
		<b>Unità OnSpot e braccio</b>				<b>Staffe per montaggio al veicolo</b>	
1	56-320501	Unità OnSpot sinistra (n°identificativo 56-319000)	1	10a	56-245901	Staffa sinistra	1
	56-320502	Unità OnSpot destra (n°identificativo 56-318900)	1	10b	56-245902	Staffa destra	1
2	56-320400	Supporto del flessibile	2	11	36-013100	Dado M16 nylock	4
3	56-320601	Manovella d'arresto sinistra, completa (n°identificativo 56-318803)	1	12	37-000700	Rondella 17x30x3	8
	56-320602	Manovella d'arresto destra, completa (n°identificativo 56-318804)	1	13	35-033500	Vite M16x70	4
4	56-321001	Braccio sinistro, incl. pos. 5 (n°identificativo 56-320201)	1	14	56-193700	Distanziale	2
	56-321002	Braccio destro, incl. pos. 5 (n°identificativo 56-320202)	1				
5	56-320700	Elementi di fissaggio del braccio	2				

VBG si riserva il diritto di modifica senza preavviso.

LV

**56-245900 56-320000**

Poz.	Det.nr.	Nosaukums	Skaits	Poz.	Det.nr.	Nosaukums	Skaits
		<b>OnSpot agregāts un svira</b>				<b>Automašīnas kronšteins</b>	
1	56-320501	OnSpot agregāts, kreisais (marķējuma № 56-319000)	1	10a	56-245901	Automašīnas kronšteins, kreisais	1
	56-320502	OnSpot agregāts, labais (marķējuma № 56-318900)	1	10b	56-245902	Automašīnas kronšteins, labais	1
2	56-320400	Šļūtenes turētājs	2	11	36-013100	Uzgrieznis M16 nylock	4
3	56-320601	Izslēgšanas poga, kreisā, komplekts, (marķējuma № 56-318803)	1	12	37-000700	Paplāksne 17x30x3	8
	56-320602	Izslēgšanas poga, labā, komplekts, (marķējuma № 56-318804)	1	13	35-033500	Skrūve M16x70	4
4	56-321001	Svira, kreisā, iesk. poz. 5 (marķējuma № 56-320201)	1	14	56-193700	Starplplāksne	2
	56-321002	Svira, labā, iesk. poz. 5 (marķējuma № 56-320202)	1				
5	56-320700	Sviru stiprinājumi	2				

VBG PRODUKTER AB saglabā tiesības izdarīt izmaiņas izstrādājumu konstrukcijās.

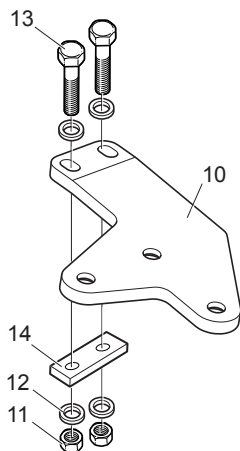
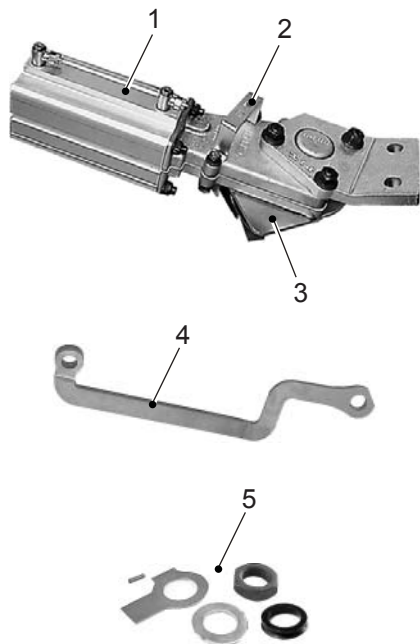

**NO 56-245900 56-320000**

Pos	Art.nr	Navn	Antall	Pos	Art.nr	Navn	Antall
		<b>Onspotaggregat og arm</b>				<b>Bilfeste</b>	
1	56-320501	Onspot-aggregat venstre (identifikationsnr 56-319000)	1	10a	56-245901	Bilfeste venstre	1
	56-320502	Onspot-aggregat høyre (identifikationsnr 56-318900)	1	10b	56-245902	Bilfeste høyre	1
2	56-320400	Slangeholder	2	11	36-013100	Mutter M16 nylock	4
3	56-320601	Stopperatt venstre, komplett (identifikationsnr 56-318803)	1	12	37-000700	Skive 17x30x3	8
	56-320602	Stopperatt høyre, komplett (identifikationsnr 56-318804)	1	13	35-033500	Skrue M16x70	4
4	56-321001	Arm venstre inkl. inkl. pos. 5 (identifikationsnr 56-320201)	1	14	56-193700	Avstandsplate	2
	56-321002	Arm høyre inkl. inkl. pos. 5 (identifikationsnr 56-320202)	1				
5	56-320700	Festedetaljer for arm	2				

VBG PRODUKTER AB forbeholder seg retten til konstruksjonsendringer

PL

**56-245900 56-320000**

Poz.	Nr części	Nazwa	Ilość	Poz.	Nr części	Nazwa	Ilość
<b>Urządzenie OnSpot i ramię</b>				<b>Zamocowanie do pojazdu</b>			
1	56-320501	Urządzenie OnSpot strona lewa (wybity numer 56-319000)	1	10a	56-245901	Zamocowanie do pojazdu, lewe	1
	56-320502	Urządzenie OnSpot strona prawa (wybity numer 56-318900)	1	10b	56-245902	Zamocowanie do pojazdu, prawe	1
2	56-320400	Uchwyt przewodu giętkiego	2	11	36-013100	Nakrętka M16 nylock	4
3	56-320601	Pokrętko oporowe lewe, komplet (wybity numer 56-318803)	1	12	37-000700	Podkładka 17x30x3	8
	56-320602	Pokrętko oporowe prawo, komplet (wybity numer 56-318804)	1	13	35-033500	Śruba M16x70	4
4	56-321001	Ramię lewe, włącznik z poz. 5 (wybity numer 56-320201)	1	14	56-193700	Metalowy element odległościowy	2
	56-321002	Ramię prawe, włącznik z poz. 5 (wybity numer 56-320202)	1				
5	56-320700	Arm fasteners	2				

VBG PRODUKTER AB zastrzega sobie prawo wprowadzania zmian produktów bez uprzedzenia.

SE

**56-245900 56-320000**

Pos	Det.nr	Benämning	Antal	Pos	Det.nr	Benämning	Antal
<b>OnSpotaggregat och arm</b>				<b>Bilfäste</b>			
1	56-320501	OnSpotaggregat vänster (instansat nr 56-319000)	1	10a	56-245901	Bilfäste, vänster	1
	56-320502	OnSpotaggregat höger (instansat nr 56-318900)	1	10b	56-245902	Bilfäste, höger	1
2	56-320400	Slanghållare	2	11	36-013100	Mutter M16 nylock	4
3	56-320601	Stoppvred vänster, komplett (instansat nr 56-318803)	1	12	37-000700	Bricka 17x30x3	8
	56-320602	Stoppvred höger, komplett (instansat nr 56-318804)	1	13	35-033500	Skruv M16x70	4
4	56-321001	Arm vänster inkl. pos. 5 (instansat nr 56-320201)	1	14	56-193700	Distansplåt	2
	56-321002	Arm höger inkl. pos. 5 (instansat nr 56-320202)	1				
5	56-320700	Fästdetaljer för arm	2				

VBG PRODUKTER AB förbehåller sig rätten till konstruktionsförändringar.





