

Mounting instructions

2010-05-17 38-230500a

Iveco Daily
56-254000
56-322001

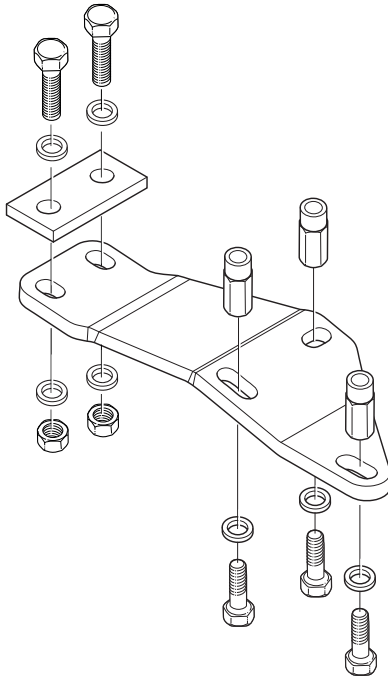

DE Blattfederung

DK Bladfjedre

FI Lehtijousitus

FR Suspension à lames

GB Plate suspension

IT Sospensioni a balestra



LV Plāksnes pakarināšana

NO Bladfjæring

PL Zawieszenie płytki

SE Bladfjädring

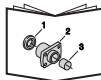
ONSPOT

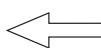
	Montageanleitung Monteringvejledning Asennusohje	Instructions de montage Mounting instruction Istruzioni di montaggio	Montāžas instrukcija Monteringsanvisning Instrukcja montażowa Monteringsanvisning
	Ersatzteilliste Reservedelsliste Varaosaluettelo	Liste des pièces détachées Spare Parts List Parti di ricambio	Rezerves daļu saraksts Reservedelliste Lista czæúci zamiennych Reservdelslista
	Anleitungen des Herstellers Producentens anvisning Valmistajan ohjeet	Instructions du fabricant Manufacturer's instruction Istruzioni del produttore	Ražotāja norādījumi Produsentens anvisning Wskazówki producenta Tillverkarens anvisning
	Anweisungen des LKW-Herstellers Lastbilfabrikantens anvisning Ajoneuvon valmistajan ohjeet Instruction du constructeur Vehicle manufacture instruction	Istruzioni del produttore del carrello Autorūpņicas instrukcija Lastebilproducentens anvisning Instrukcja producenta pojazdu Lastvagnstillverkarens anvisning	
	Fahrtrichtung Kørselsretning Ajosuunta	Sens de conduite Direction of travel Senso di marcia	Kustības virziens Kjøreretning Kierunek jazdy Färdriktning

Allgemein

Die Montage darf nur von ausgebildetem und kompetentem Fachpersonal durchgeführt werden und muß in einer befugten Werkstatt erfolgen, die über erforderliche Werkzeuge und Ausrüstungen verfügt, und in der Zugänglichkeit und Sicherheit gegeben sind. Alle Teile vor der Montage identifizieren. Anweisungen befolgen.

Empfohlene Einstellungen nicht ändern. Übergeben Sie dem Kunden alle Anweisungen und Instruktionen zur Aufbewahrung im Fahrzeug für künftige Service- und Wartungsarbeiten.

 Befolgen Sie die Anweisungen des LKW-Herstellers

Generelt

Monteringen skal foretages af uddannet og kompetent personale og ske på autoriseret værksted, der råder over det nødvendige værktøj og udstyr, og hvor der sikres tilgængelighed og sikkerhed. Kontroller at alle dele er til stede inden montering. Følg anvisningerne.

Anbefalede indstillinger må ikke ændres. Giv kunden alle anvisninger og instruktioner, så de kan lægges i bilen til brug ved fremtidig service og vedligeholdelse.

 Følg lastbilfabrikantens anvisninger



Yleistä

Laitteisto on asennettava valtuutetussa korjaamossa, jonka koulutetulla ja ammattitaitoisella henkilökunnalla on käytössään tarvittavat työkalut ja varusteet ja jossa on turvalliset työskentelyolot. Tunnista kaikki osat ennen asennusta. Noudata ohjeita.

Älä muuta suositeltuja säätöjä. Luovuta kaikki ohjeet asiakkaalle säilytettäväksi autossa tulevia huoltoja ja kunnossapitoa varten.



Noudata ajoneuvon valmistajan ohjeita



Généralités

Le montage doit être effectué par des personnes possédant la compétence et la formation requises, dans un atelier autorisé disposant des outils et équipements nécessaires et où l'accessibilité et la sécurité peuvent être assurées. Identifier tous les composants avant de procéder au montage. Suivre les instructions.

Ne pas modifier les réglages recommandés. Toutes les informations et toutes les instructions doivent être remises au client afin d'être conservées dans le véhicule et utilisées pour les opérations d'entretien futures.



Se conformer également aux instructions du constructeur du camion



General

Installation work should be carried out by trained and skilled staff. It should be performed at an authorised workshop where the required tools and equipment are available and where provisions can be made for accessibility and safety. Identify all components prior to installation. Follow the instructions.

Do not alter the recommended settings. Give the customer all directives and instructions so that these can be kept in the vehicle for future service and maintenance.



Follow the instructions of the vehicle manufacturer



Generalità

Il montaggio deve essere effettuato da personale competente e dotato della formazione richiesta, in una officina autorizzata, in possesso delle necessarie attrezzature e dove accessibilità e sicurezza possano essere garantite. Identificare tutti i componenti prima di procedere al montaggio. Seguire le istruzioni.

Non modificarne le raccomandazioni. Tutte le informazioni e tutte le istruzioni devono essere trasmesse al cliente e conservate a corredo del veicolo per essere utilizzate nelle operazioni di successiva manutenzione.



Attenersi altresì alle istruzioni del costruttore del veicolo.



Vispārēji norādījumi

Uzstādīšanas darbi jāveic trenētām un apmācītam personālam. Tie jāizpilda autorizētā darbnīcā, kur ir pieejami nepieciešamie darbarīki un aprīkojums un kur ir nepieciešamie nosacījumi, lai nodrošinātu piekļuvi un drošību. Pirms montāžas identificējiet visas detaļas. Sekojiet norādījumiem. Neizmainiet ieteiktos iestatījumus. Visus norādījumus un instrukcijas izsniedziet klientam, lai tās tiktu uzglabātas automobilī un būtu pieejamas servisa un apkopes gadījumos.



Ievērojiet automašīnas izgatavotāja instrukcijas.



Generelt

Monteringen skal utføres av kompetent personell med nød-vendig opplæring, og skal skje på autorisert verksted hvor nødvendig verktøy og utstyr er tilgjengelig og sikkerheten kan ivaretas. Identifiser alle deler før montering. Følg anvisningene.

Ikke foreta endringer av anbefalte innstillinger. Overlever alle anvisninger og instruksjoner til kunden for oppbevaring i kjøretøyet for fremtidig service og vedlikehold.



Følg lastebilprodusentens anvisninger



Informacje ogólne

Montaż powinien być wykonywany wyłącznie przez przeszkolonych i kompetentnych pracowników. Powinien być wykonany w autoryzowanym punkcie obsługi technicznej, gdzie znajdują się wymagane narzędzia i wyposażenie oraz gdzie może być zapewniony odpowiedni dostęp i bezpieczeństwo. Zapoznaj się z poszczególnymi częściami przed przystąpieniem do montażu. Stosuj się do instrukcji. Nie zmieniaj zalecanych ustawień. Wszystkie wskazówki i instrukcje należy przekazać klientowi w celu przechowywania ich w pojeździe i wykorzystywania przy okazji przyszłych czynności serwisowych i konserwacyjnych.



Postępuj zgodnie z instrukcją producenta pojazdu.



Allmänt

Monteringen skall utföras av utbildad och kompetent personal och ske på auktoriserad verkstad där erforderliga verktyg och utrustning finns och där åtkomlighet och säkerhet kan tillgodoses. Identifiera alla delar före montering. Följ anvisningarna.

Ändra ej rekommenderade inställningar. Lämna alla anvisningar och instruktioner till kunden att förvaras i fordonet för framtida service och underhåll.



Följ lastvagnstillverkarens anvisningar

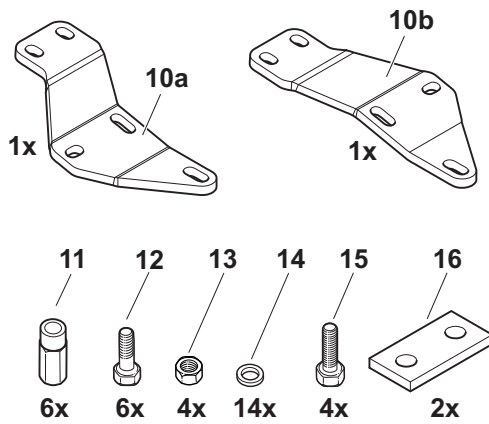
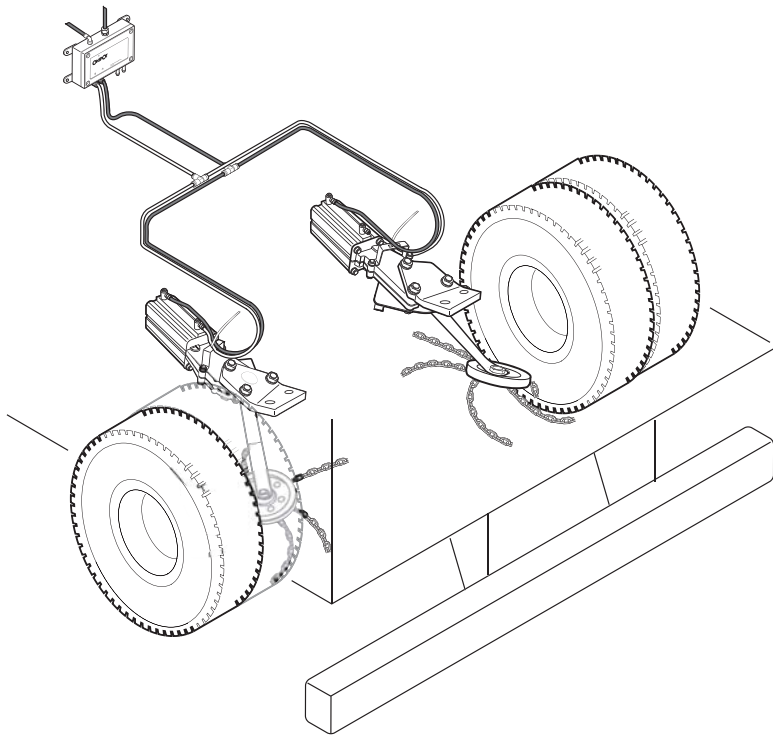

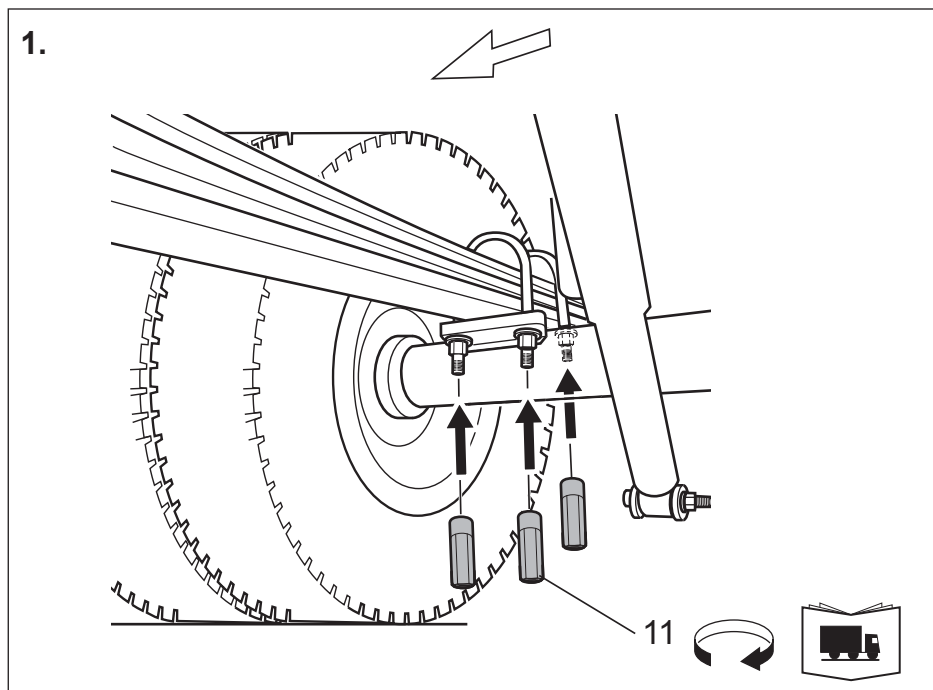

2.

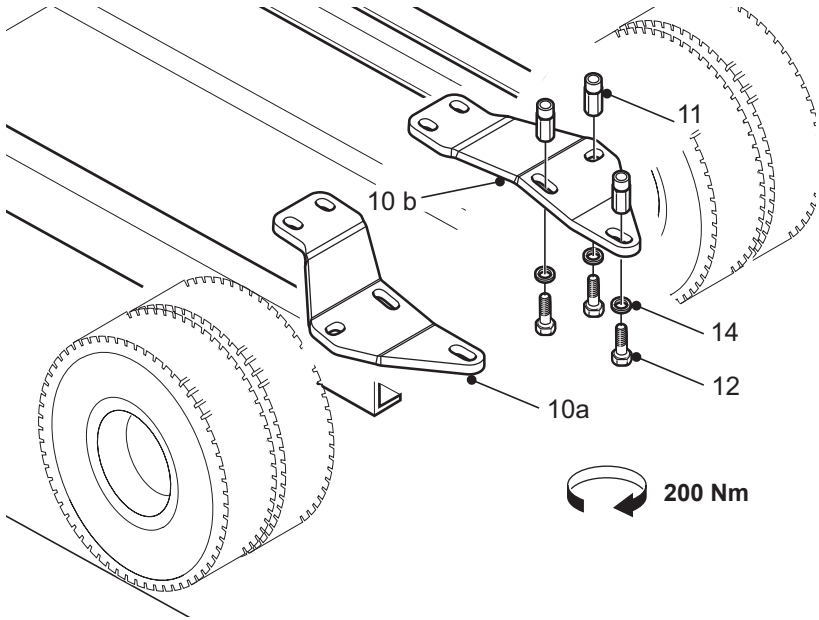

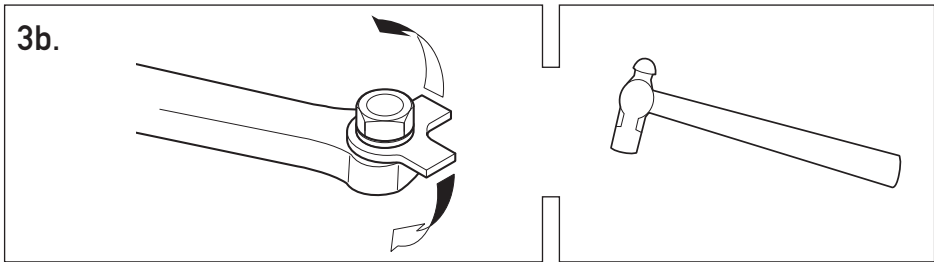
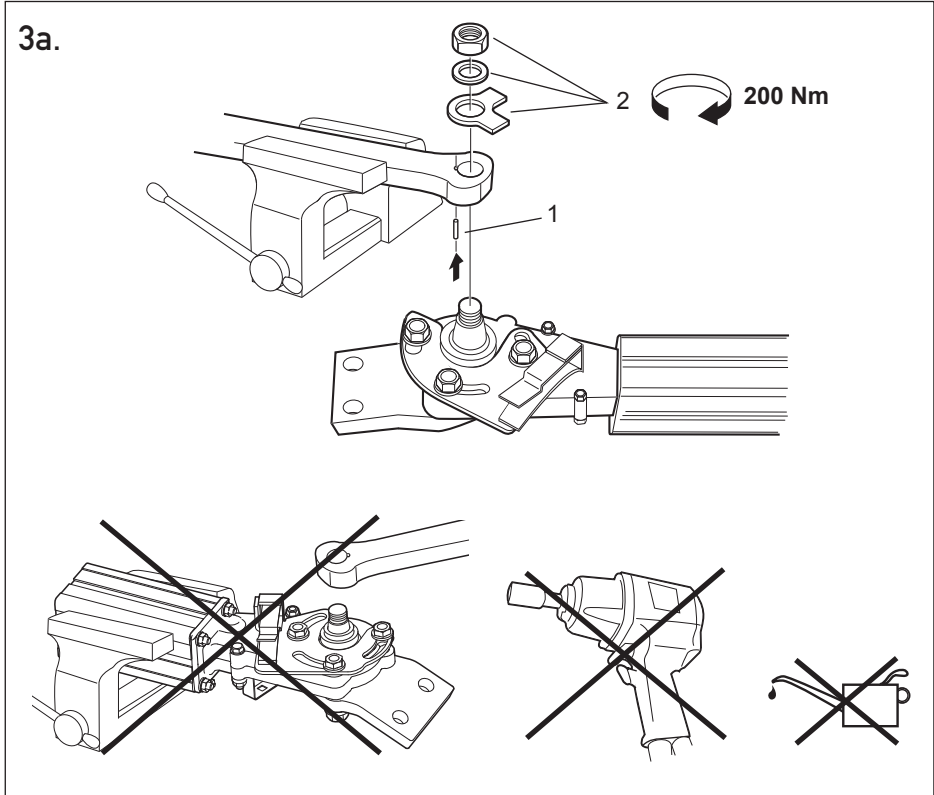
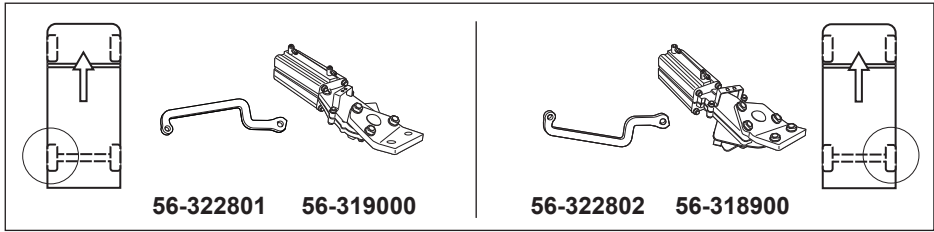

4.

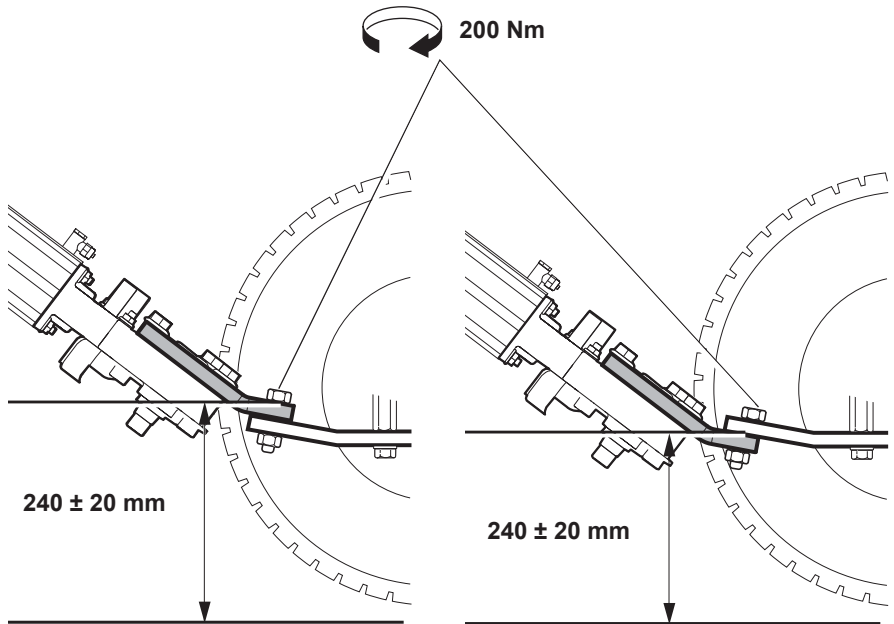
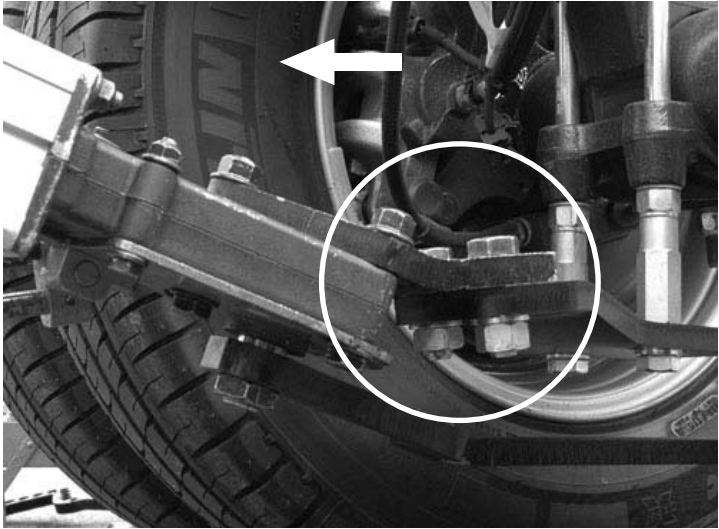

4.

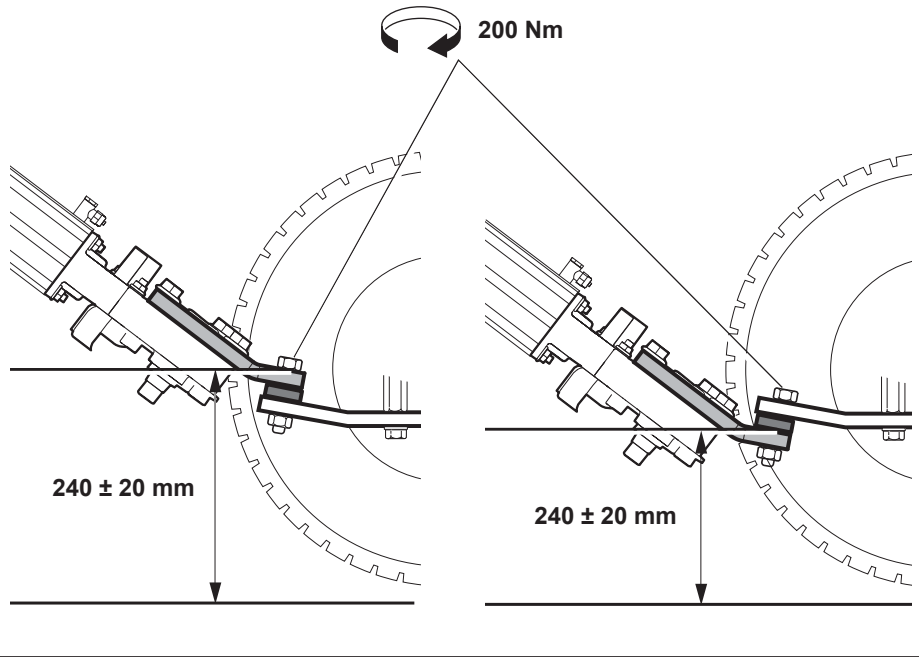

5.

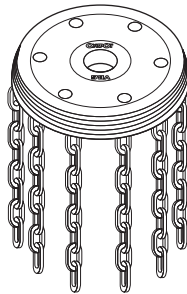

38-155900

6.

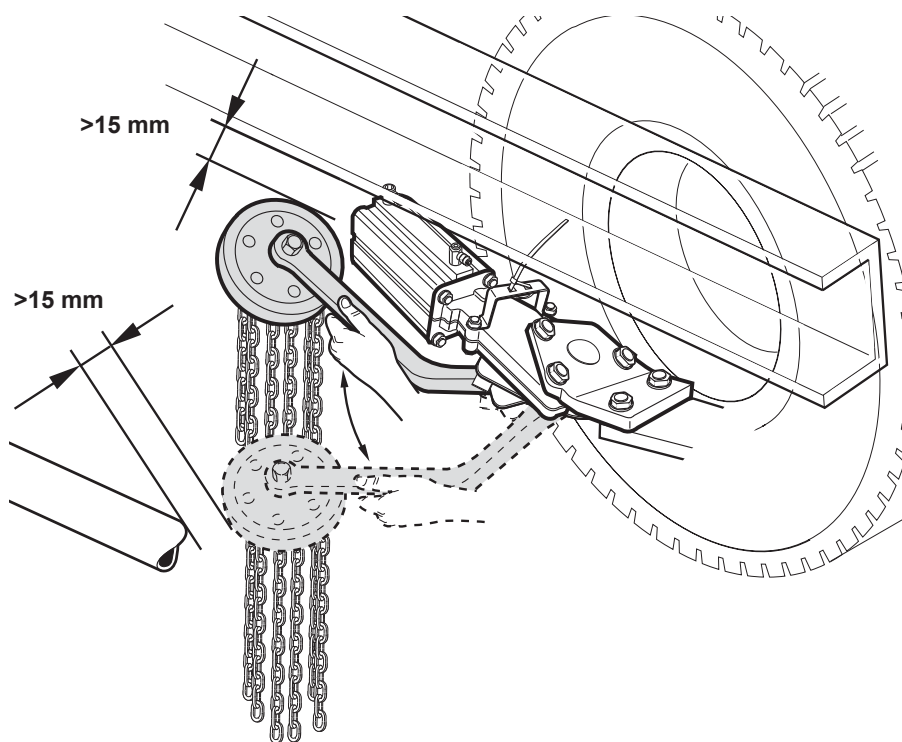
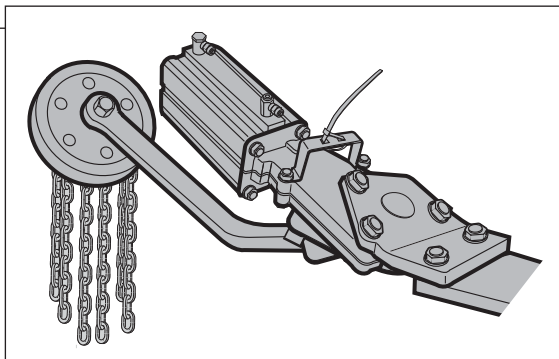

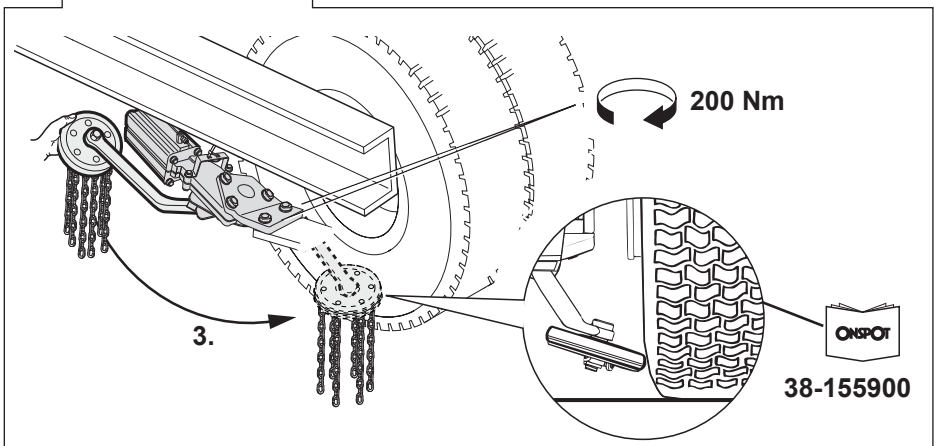
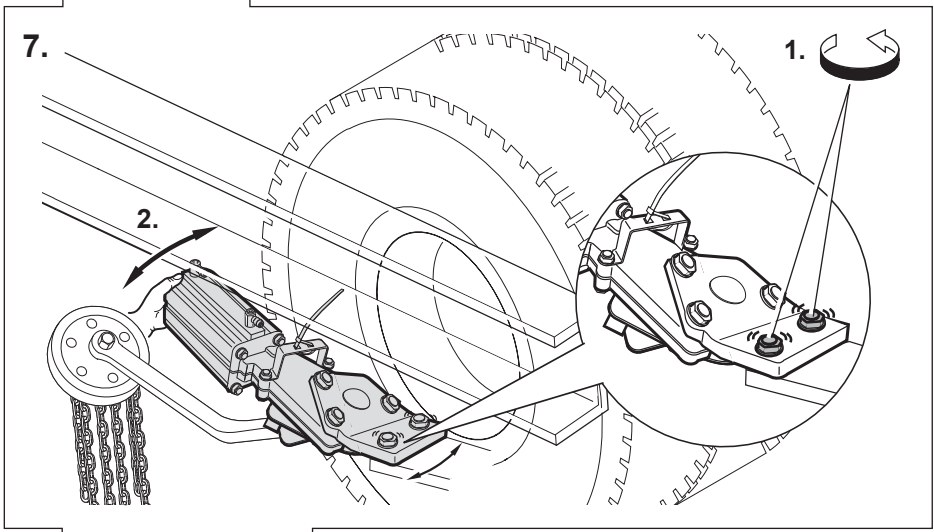
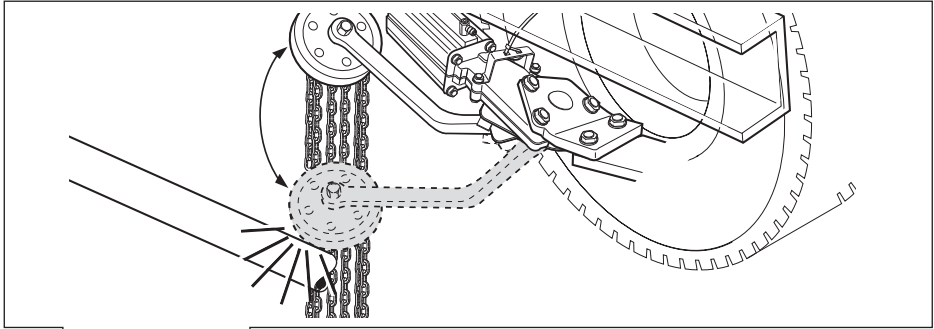

8.

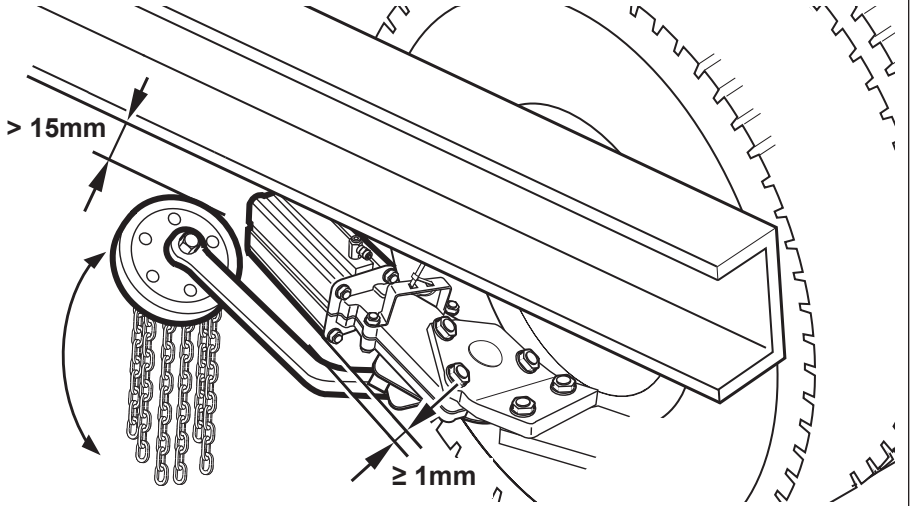
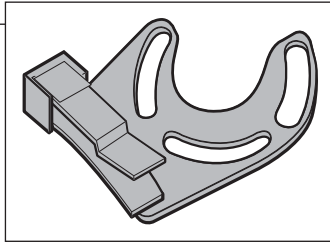

9.

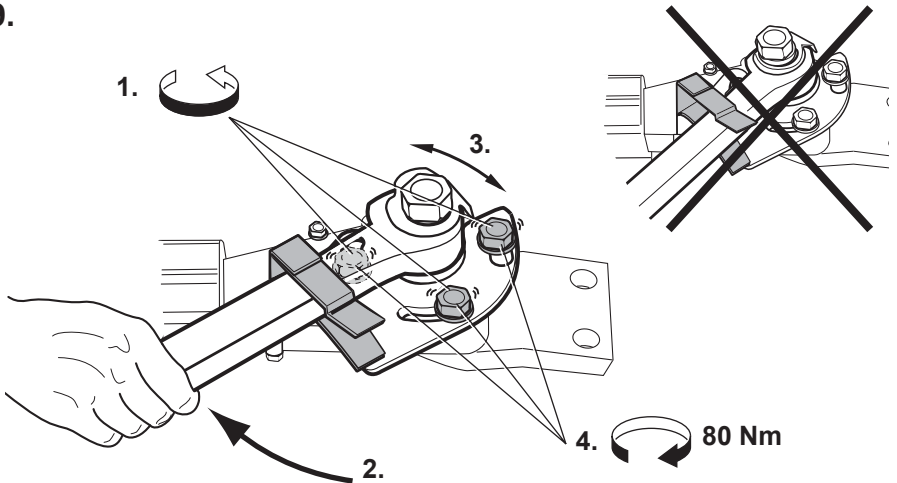

10.

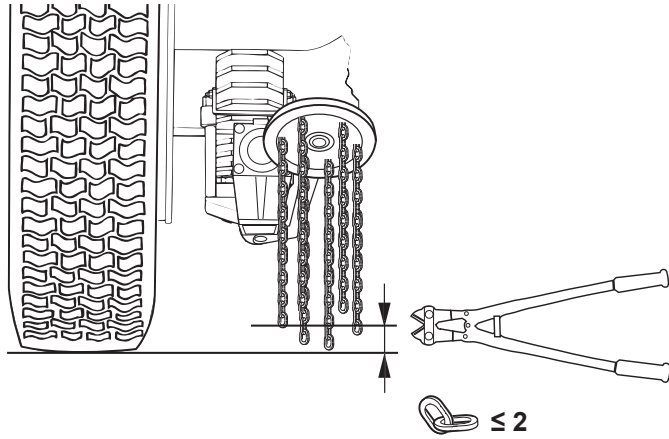
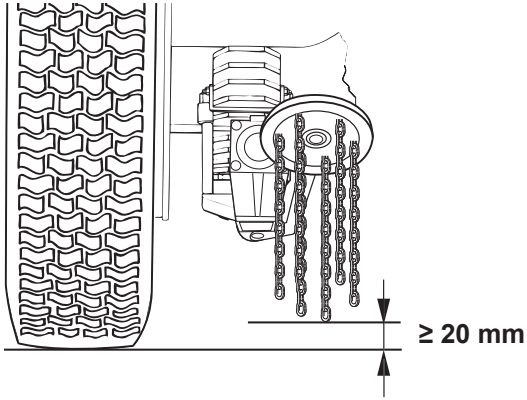

11.

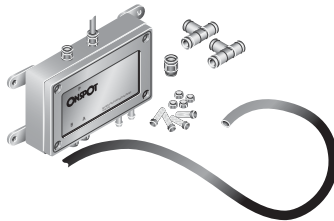

38-050700

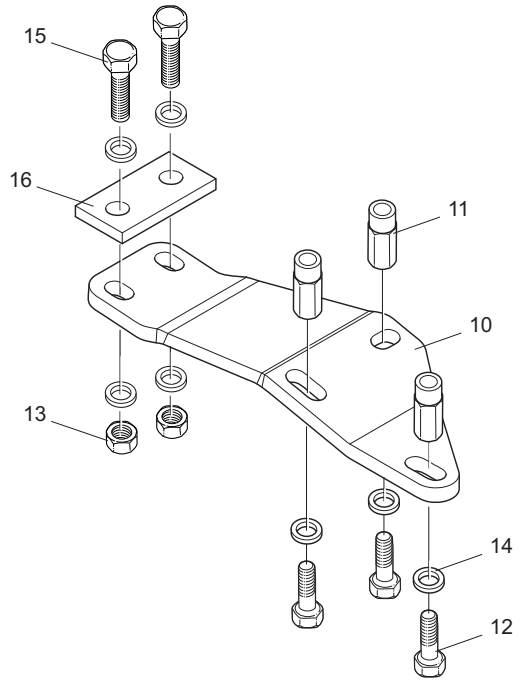
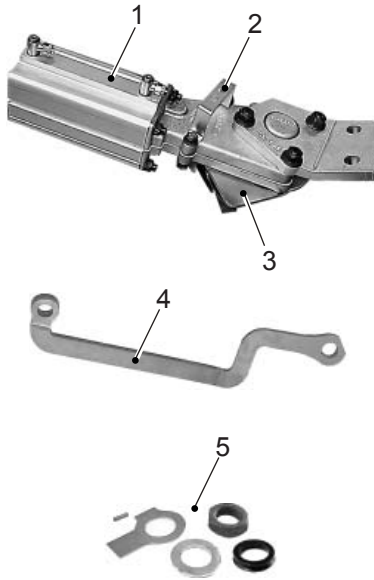
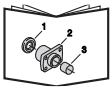

DE 56-254000 56-322001

Pos	Art.-nr	Bezeichnung	Anzahl	Pos	Det.nr	Bezeichnung	Anzahl
Onspotaggregat und Arm				Adapterplatten			
1	56-320501	Onspot-Aggregat links (Stanznummer 56-319000)	1	10a	56-251201	Adapterplatte links	1
	56-320502	Onspot-Aggregat rechts (Stanznummer 56-318900)	1	10b	56-251202	Adapterplatte rechts	1
2	56-320400	Schlauchhalter	2	11	56-109804	Doppelmuttern M16	6
3	56-320601	Stopper links, komplett (Stanznummer 56-318803)	1	12	35-032900	Schraube M16x35	6
	56-320602	Stopper rechts, komplett (Stanznummer 56-318804)	1	13	36-013100	Mutter M16 Nylock	4
4	56-321017	Arm links inkl. pos. 5 (Stanznummer 56-322801)	1	14	37-000700	Scheibe 17x30x3	14
	56-321018	Arm rechts inkl. pos. 5 (Stanznummer 56-322802)	1	15	35-033500	Schraube M16x70	4
5	56-320700	Befestigungsteile für Arm	2	16	56-193700	Distanzplatte	2

Die VBG GROUP TRUCK EQUIPMENT AB behält sich das Recht auf Konstruktionsänderungen vor.

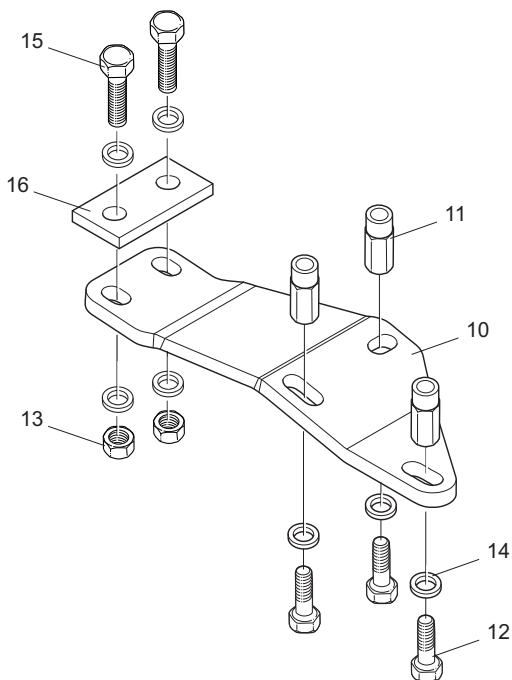
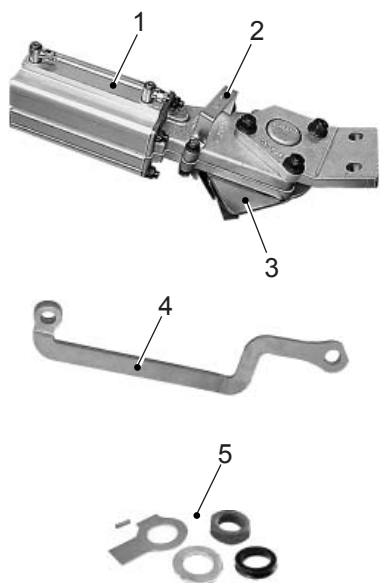

DK 56-254000 56-322001

Pos	Art.nr.	Betegnelse	Antal	Pos	Art.nr.	Betegnelse	Antal
		Onspotaggregat og arm				Konsol	
1	56-320501	Onspotaggregat venstre (ihugget nr. 56-319000)	1	10a	56-251201	Konsol venstre	1
	56-320502	Onspotaggregat højre (ihugget nr. 56-318900)	1	10b	56-251202	Konsol højre	1
2	56-320400	Slangeholder	2	11	56-109804	Dobbeltmøtrik M16	6
3	56-320601	Stop venstre, komplet (ihugget nr. 56-318803)	1	12	35-032900	Bolt M16x35	6
	56-320602	Stop højre, komplet (ihugget nr. 56-318804)	1	13	36-013100	Møtrik M16 Nylock	4
4	56-321017	Arm venstre inkl. pos. 5 (ihugget nr. 56-322801)	1	14	37-000700	Skive 17x30x3	14
	56-321018	Arm højre inkl. pos. 5 (ihugget nr. 56-322802)	1	15	35-033500	Bolt M16x70	4
5	56-320700	Monteringsdele til arm	2	16	56-193700	Avstandsplade	2

VBG GROUP TRUCK EQUIPMENT AB forbeholder sig retten til konstruktionsændringer.

FI

56-254000 56-322001

Pos	Tuote no	Nimitys	Kpl	Pos	Tuote no	Nimitys	Kpl
Onspot-laite ja varsi				Autokiinnike			
1	56-320501	Vasen Onspot-laite (meistetty nro 56-319000)	1	10a	56-251201	Vasen autokiinnike	1
	56-320502	Oikea Onspot-laite (meistetty nro 56-318900)	1	10b	56-251202	Oikea autokiinnike	1
2	56-320400	Letkupidin	2	11	56-109804	Kaksoismutteri M16	6
3	56-320601	Vasen rajoitinasennelma (meistetty nro 56-318803)	1	12	35-032900	Ruuvi M16x35	6
	56-320602	Oikea rajoitinasennelma (meistetty nro 56-318804)	1	13	36-013100	Mutteri M16 Nylock	4
4	56-321017	Vasen varsi sis. pos. 5 (meistetty nro 56-322801)	1	14	37-000700	Aluslevy 17x30x3	14
	56-321018	Oikea varsi sis. pos. 5 (meistetty nro 56-322802)	1	15	35-033500	Ruuvi M16x70	4
5	56-320700	Varren asennusosat	2	16	56-193700	Välilevy	2

VBG GROUP TRUCK EQUIPMENT AB pidättää oikeuden muuttaa rakennetta.

FR

56-254000 56-322001

Pos	N°d'art.	Désignation	Qté	Pos	N°d'art.	Désignation	Qté
Groupe Onspot et bras				Fixation voiture			
1	56-320501	Groupe Onspot gauche (No. 56-319000)	1	10a	56-251201	Fixation voiture gauche	1
	56-320502	Groupe Onspot droit (No. 56-318900)	1	10b	56-251202	Fixation voiture droit	1
2	56-320400	Support de tuyaux	2	11	56-109804	Écrou double M16	6
3	56-320601	Manivelle d'arrêt gauche complète (No. 56-318803)	1	12	35-032900	Vis M16x35	6
	56-320602	Manivelle d'arrêt droit complète (No. 56-318804)	1	13	36-013100	Écrou M16 Nylock	4
4	56-321017	Bras gauche, avec pos. 5 (No. 56-322801)	1	14	37-000700	Rondelle 17x30x3	14
	56-321018	Bras droit, avec pos. 5 (No. 56-322802)	1	15	35-033500	Vis M16x70	4
5	56-320700	Éléments de fixation du bras	2	16	56-193700	Tôle entretoise	2

VBG GROUP TRUCK EQUIPMENT AB se réserve le droit de modifier ses constructions.

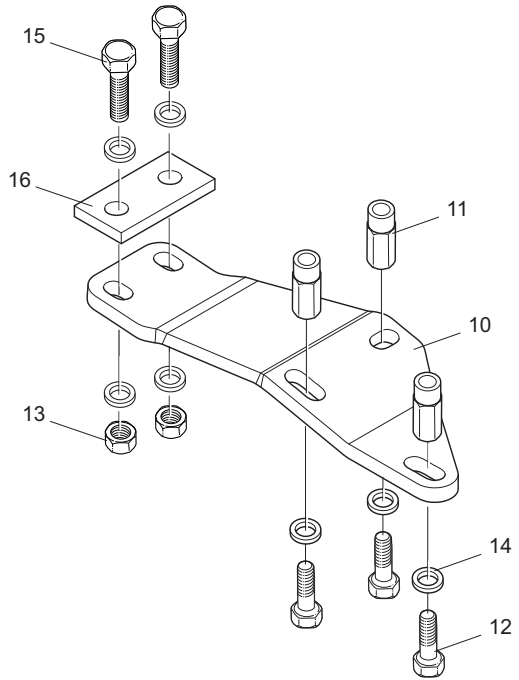
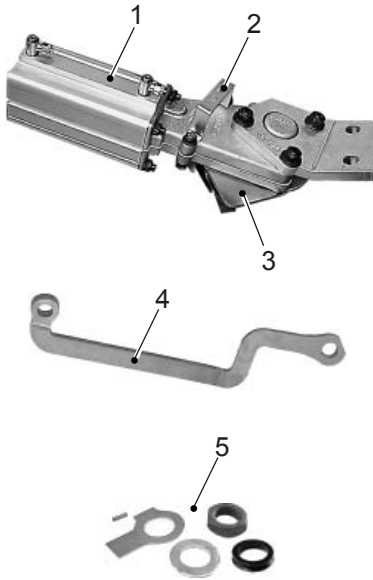

GB 56-254000 56-322001

Pos	Part no.	Description	Qty	Pos	Part no.	Description	Qty
Onspot-unit and arm				Vehicle bracket			
1	56-320501	Onspot unit left (stamped no. 56-319000)	1	10a	56-251201	Vehicle bracket left	1
	56-320502	Onspot unit right (stamped no. 56-318900)	1	10b	56-251202	Vehicle bracket right	1
2	56-320400	Hose holder	2	11	56-109804	Double nut M16	6
3	56-320601	Stop knob left, complete (stamped no. 56-318803)	1	12	35-032900	Screw M16x35	6
	56-320602	Stop knob right, complete (stamped no. 56-318804)	1	13	36-013100	Nut M16 Nylock	4
4	56-321017	Arm left, incl. pos. 5 (stamped no. 56-322801)	1	14	37-000700	Washer 17x30x3	14
	56-321018	Arm right, incl. pos. 5 (stamped no. 56-322802)	1	15	35-033500	Screw M16x70	4
5	56-320700	Arm fasteners	2	16	56-193700	Spacing plate	2

VBG GROUP TRUCK EQUIPMENT AB reserve the right to amend or alter specifications at their discretion.

IT

56-254000 56-322001

Pos.	Codice	Descrizione	Q	Pos.	Codice	Descrizione	Q
		Unità Onspot e braccio				Staffe per montaggio al veicolo	
1	56-320501	Unità Onspot sinistra (n°identificativo 56-319000)	1	10a	56-251201	Staffa sinistra	1
	56-320502	Unità Onspot destra (n°identificativo 56-318900)	1	10b	56-251202	Staffa destra	1
2	56-320400	Supporto del flessibile	2	11	56-109804	Dado doppio M16	6
3	56-320601	Manovella d'arresto sinistra, completa (n°identificativo 56-318803)	1	12	35-032900	Vite M16x35	6
	56-320602	Manovella d'arresto destra, completa (n°identificativo 56-318804)	1	13	36-013100	Dado M16 Nylock	4
4	56-321017	Braccio sinistro, incl. pos. 5 (n°identificativo 56-322801)	1	14	37-000700	Rondella 17x30x3	14
	56-321018	Braccio destro, incl. pos. 5 (n°identificativo 56-322802)	1	15	35-033500	Vite M16x70	4
5	56-320700	Elementi di fissaggio del braccio	2	16	56-193700	Distanziale	2

VBG GROUP TRUCK EQUIPMENT AB si riserva il diritto di modifica senza preavviso.

LV

56-254000 56-322001

Pozīcija	Det.nr.	Nosaukums	Skaits	Pozīcija	Det.nr.	Nosaukums	Skaits
		OnSpot agregāts un svira				Automašīnas kronšteins	
1	56-320501	OnSpot agregāts, kreisais (marķējuma № 56-319000)	1	10a	56-251201	Automašīnas kronšteins, kreisais	1
	56-320502	OnSpot agregāts, labais (marķējuma № 56-318900)	1	10b	56-251202	Automašīnas kronšteins, labais	1
2	56-320400	Šļūtenes turētājs	2	11	56-109804	Dubultuzgrieznis M16	6
3	56-320601	Izslēgšanas poga, kreisā, komplekts, (marķējuma № 56-318803)	1	12	35-032900	Skrūve M16x35	6
	56-320602	Izslēgšanas poga, labā, komplekts, (marķējuma № 56-318804)	1	13	36-013100	Uzgrieznis M16 Nylock	4
4	56-321017	Svira, kreisā, iesk. poz. 5 (marķējuma № 56-322801)	1	14	37-000700	Paplāksne 17x30x3	14
	56-321018	Svira, labā, iesk. poz. 5 (marķējuma № 56-322802)	1	15	35-033500	Skrūve M16x70	4
5	56-320700	Sviru stiprinājumi	2	16	56-193700	Starplāksne	2

VBG GROUP TRUCK EQUIPMENT AB saglabā tiesības izdarīt izmaiņas izstrādājumu konstrukcijās.

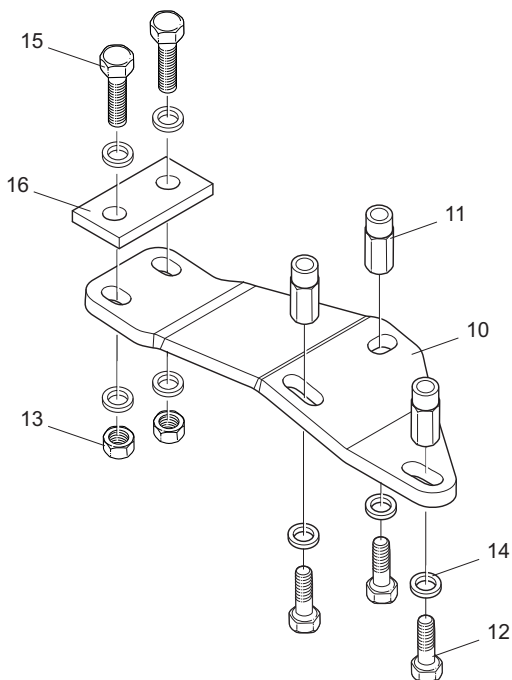
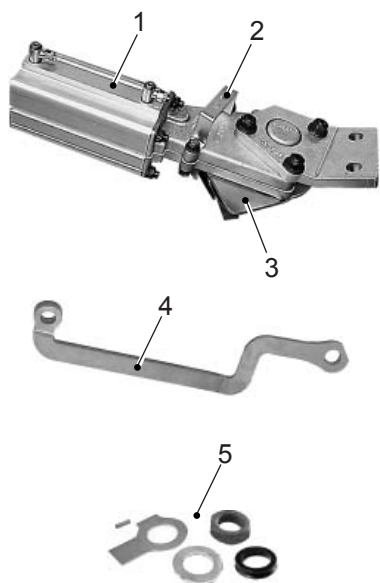

NO 56-254000 56-322001

Pos	Art.nr	Navn	Antall	Pos	Art.nr	Navn	Antall
		Onspotaggregat og arm				Bilfeste	
1	56-320501	Onspot-aggregat venstre (identifikationsnr 56-319000)	1	10a	56-251201	Bilfeste venstre	1
	56-320502	Onspot-aggregat høyre (identifikationsnr 56-318900)	1	10b	56-251202	Bilfeste høyre	1
2	56-320400	Slangeholder	2	11	56-109804	Dobbeltmutter M16	6
3	56-320601	Stopperatt venstre, komplett (identifikationsnr 56-318803)	1	12	35-032900	Skrue M16x35	6
	56-320602	Stopperatt høyre, komplett (identifikationsnr 56-318804)	1	13	36-013100	Mutter M16 Nylock	4
4	56-321017	Arm venstre inkl. pos. 5 (identifikationsnr 56-322801)	1	14	37-000700	Skive 17x30x3	14
	56-321018	Arm høyre inkl. pos. 5 (identifikationsnr 56-322802)	1	15	35-033500	Skrue M16x70	4
5	56-320700	Festedetaljer for arm	2	16	56-193700	Avstandsplate	2

VBG GROUP TRUCK EQUIPMENT AB forbeholder seg retten til konstruksjonsendringer.

PL

56-254000 56-322001

Poz.	Nr części	Nazwa	Ilość	Poz.	Nr części	Nazwa	Ilość
Urządzenie Onspot i ramię				Zamocowanie do pojazdu			
1	56-320501	Urządzenie Onspot strona lewa (wybity numer 56-319000)	1	10a	56-251201	Zamocowanie do pojazdu, lewe	1
	56-320502	Urządzenie Onspot strona prawa (wybity numer 56-318900)	1	10b	56-251202	Zamocowanie do pojazdu, prawe	1
2	56-320400	Uchwyt przewodu giętkiego	2	11	56-109804	Nakrętka podwójna M16	6
3	56-320601	Pokrętło oporowe lewe, komplet (wybity numer 56-318803)	1	12	35-032900	Śruba M16x35	6
	56-320602	Pokrętło oporowe prawo, komplet (wybity numer 56-318804)	1	13	36-013100	Nakrętka M16 Nylock	4
4	56-321017	Ramię lewe, włącznie z poz. 5 (wybity numer 56-322801)	1	14	37-000700	Podkładka 17x30x3	14
	56-321018	Ramię prawo, włącznie z poz. 5 (wybity numer 56-322802)	1	15	35-033500	Śruba M16x70	4
5	56-320700	Elementy mocujące ramienia	2	16	56-193700	Metalowy element odległościowy	2

VBG GROUP TRUCK EQUIPMENT AB zastrzega sobie prawo wprowadzania zmian produktów bez uprzedzenia.

SE

56-254000 56-322001

Pos	Det.nr	Benämning	Antal	Pos	Det.nr	Benämning	Antal
Onspotaggregat och arm				Bilfäste			
1	56-320501	Onspotaggregat vänster (instansat nr 56-319000)	1	10a	56-251201	Bilfäste VF	1
	56-320502	Onspotaggregat höger (instansat nr 56-318900)	1	10b	56-251202	Bilfäste HF	1
2	56-320400	Slanghållare	2	11	56-109804	Dubbelmutter M16	6
3	56-320601	Stoppvred vänster, komplett (instansat nr 56-318803)	1	12	35-032900	Skruv M16x35	6
	56-320602	Stoppvred höger, komplett (instansat nr 56-318804)	1	13	36-013100	Mutter M16 Nylock	4
4	56-321017	Arm vänster inkl. pos. 5 (instansat nr 56-322801)	1	14	37-000700	Bricka 17x30x3	14
	56-321018	Arm höger inkl. pos. 5 (instansat nr 56-322802)	1	15	35-033500	Skruv M16x70	4
5	56-320700	Fästdetaljer för arm	2	16	56-193700	Distansplåt	2

VBG GROUP TRUCK EQUIPMENT AB förbehåller sig rätten till konstruktionsförändringar.

