



AUTOMATIC TIRE CHAINS

VEHICLE SUSPENSION INFORMATION

Chevrolet/GM K, C & G Series
Ford - F Series
Sprinter
Dodge/Ram

Form #3130008

The following information and measurements are required in order to determine if the vehicle can be fit with Onspots, and, if so, which Model Onspot Chain Set and Mounting Bracket Kit is required. This information will be different from vehicle to vehicle based on vehicle make/model, axle make/model, tire size, and wheel offset. Any questions in completing this form can be addressed to Onspot at 800-224-2467.

Dealer or OEM name: _____

Customer name: _____ Ref. Unit No. _____

Address: _____

City: _____ State: _____ Zip: _____

Contact: _____ Phone Number: _____

Quantity of identical vehicles for this order: _____

Description: (School Bus, Service Truck, etc.) _____

Vehicle Make: _____ Model: _____ Year: _____

Note: The following information applies to the rear suspension only.

Axle Make: _____ Capacity: _____

Tire Size: _____ Brand: _____

Rear Tires: Single/Dual

Disc Brakes: Yes/No Suspension Type: Spring/Air/Other: _____

Shock on rear axle: Yes/No Shock location on rear axle: Front/Back

Shock bracket: Yes/No If yes, Shock bracket thickness (in.): _____

Torsion/Sway Bar: Yes/No Forward of axle/Behind axle

Are there any obstructions (e.g. Fuel tank, air tank, etc.) _____

Fuel tank: Rear/Side/Both Ground to axle tube: _____

Ground to Fuel tank: Rear tank: _____ Side tank: _____

Distance tire sidewall to exhaust: Forward of axle: _____ Behind axle: _____

Distance ground to exhaust: Forward of axle: _____ Behind axle: _____

VEHICLE SUSPENSION INFORMATION

Name _____ Unit # _____

(please circle) Axle Measuring FRONT / REAR

(A) The distance from the lowest part of the saddle plate to where the u-bolt nut contacts the saddle plate.
NOTE: This dimension does not apply to all axles.

(BF) The distance from the ground to where the front u-bolt nuts contact the saddle plate.

(BB) The distance from the ground to where the rear u-bolt nuts contact the saddle plate.
NOTE: If the BB or BF measurements are to the bottom of a shock bracket that is held in place by the u-bolt nuts, PLEASE INDICATE.

(C) The distance from the tire bulge (approximately 3 1/2 - 4 inches off the ground) to the center of the u-bolt closest to the tire. This measurement is best taken by hanging a plumb bob from the CENTER of the u-bolt and measuring to the tire bulge.

(D) The thread remaining below the u-bolt nuts (in inches).

(E) The thickness of the u-bolt nut (and washer if applicable).

(X) The diameter of the u-bolt. Fine or Coarse thread.
CAUTION: Some u-bolts may be metric.

(Y) The center to center distance of the u-bolts front to back.

(Z) The center to center distance of the u-bolts side to side.

Depth of Round A = _____
 Height in Front BF = _____
 Height in back BB = _____
 Sidewall Distance C = _____
 Remaining U-bolt D = _____
 Nut Height Thickness E = _____

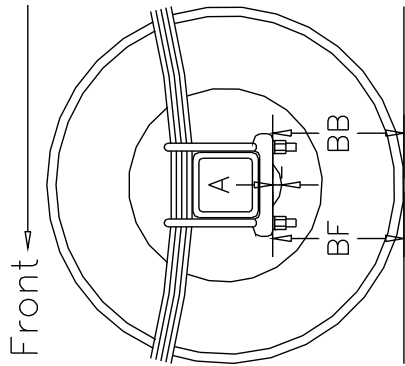

Side View

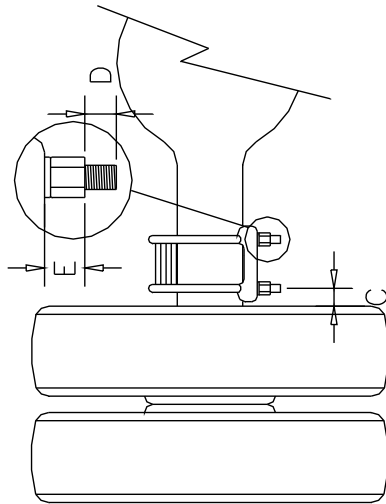

End View

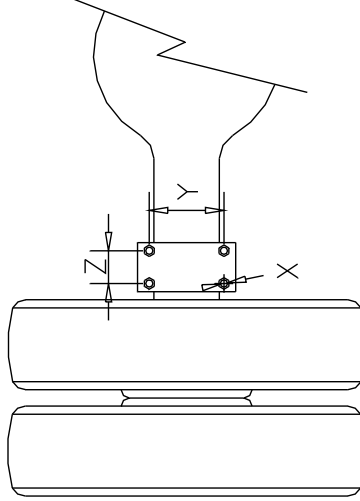

Bottom View

U-Bolt Diameter X = _____ Fine/Coarse

Distance Front to Rear Y = _____

Distance Side to Side Z = _____

QUESTIONS? 1-800-224-2467
FAX COMPLETED FORM TO: 812-346-1819
OR EMAIL TO: service@onspot.com